

Operation and Maintenance Manual

First Defense[®] High Capacity and First Defense[®] Optimum

Vortex Separator for Stormwater Treatment

Table of Contents

3	FIRST DEFENSE® BY HYDRO INTERNATIONAL <ul style="list-style-type: none">- INTRODUCTION- OPERATION- POLLUTANT CAPTURE AND RETENTION
4	MODEL SIZES & CONFIGURATIONS <ul style="list-style-type: none">- FIRST DEFENSE® COMPONENTS
5	MAINTENANCE <ul style="list-style-type: none">- OVERVIEW- MAINTENANCE EQUIPMENT CONSIDERATIONS- DETERMINING YOUR MAINTENANCE SCHEDULE
6	MAINTENANCE PROCEDURES <ul style="list-style-type: none">- INSPECTION- FLOATABLES AND SEDIMENT CLEAN OUT
8	FIRST DEFENSE® INSTALLATION LOG
9	FIRST DEFENSE® INSPECTION AND MAINTENANCE LOG

COPYRIGHT STATEMENT: The contents of this manual, including the graphics contained herein, are intended for the use of the recipient to whom the document and all associated information are directed. Hydro International plc owns the copyright of this document, which is supplied in confidence. It must not be used for any purpose other than that for which it is supplied and must not be reproduced, in whole or in part stored in a retrieval system or transmitted in any form or by any means without prior permission in writing from Hydro International plc. First Defense® is a trademarked hydrodynamic vortex separation device of Hydro International plc. A patent covering the First Defense® has been granted.

DISCLAIMER: Information and data contained in this manual is exclusively for the purpose of assisting in the operation and maintenance of Hydro International plc's First Defense®. No warranty is given nor can liability be accepted for use of this information for any other purpose. Hydro International plc has a policy of continuous product development and reserves the right to amend specifications without notice.

I. First Defense® by Hydro International

Introduction

The First Defense® is an enhanced vortex separator that combines an effective and economical stormwater treatment chamber with an integral peak flow bypass. It efficiently removes total suspended solids (TSS), trash and hydrocarbons from stormwater runoff without washing out previously captured pollutants. The First Defense® is available in several model configurations to accommodate a wide range of pipe sizes, peak flows and depth constraints.

The two product models described in this guide are the First Defense® High Capacity and the First Defense® Optimum; they are inspected and maintained identically.

Operation

The First Defense® operates on simple fluid hydraulics. It is self-activating, has no moving parts, no external power requirement and is fabricated with durable non-corrosive components. No manual procedures are required to operate the unit and maintenance is limited to monitoring accumulations of stored pollutants and periodic clean-outs. The First Defense® has been designed to allow for easy and safe access for inspection, monitoring and clean-out procedures. Neither entry into the unit nor removal of the internal components is necessary for maintenance, thus safety concerns related to confined-space-entry are avoided.

Pollutant Capture and Retention

The internal components of the First Defense® have been designed to optimize pollutant capture. Sediment is captured and retained in the base of the unit, while oil and floatables are stored on the water surface in the inner volume (Fig.1).

The pollutant storage volumes are isolated from the built-in bypass chamber to prevent washout during high-flow storm events. The sump of the First Defense® retains a standing water level between storm events. This ensures a quiescent flow regime at the onset of a storm, preventing resuspension and washout of pollutants captured during previous events.

Accessories such as oil absorbent pads are available for enhanced oil removal and storage. Due to the separation of the oil and floatable storage volume from the outlet, the potential for washout of stored pollutants between clean-outs is minimized.

Applications

- Stormwater treatment at the point of entry into the drainage line
- Sites constrained by space, topography or drainage profiles with limited slope and depth of cover
- Retrofit installations where stormwater treatment is placed on or tied into an existing storm drain line
- Pretreatment for filters, infiltration and storage

Advantages

- Inlet options include surface grate or multiple inlet pipes
- Integral high capacity bypass conveys large peak flows without the need for “offline” arrangements using separate junction manholes
- Long flow path through the device ensures a long residence time within the treatment chamber, enhancing pollutant settling
- Delivered to site pre-assembled and ready for installation

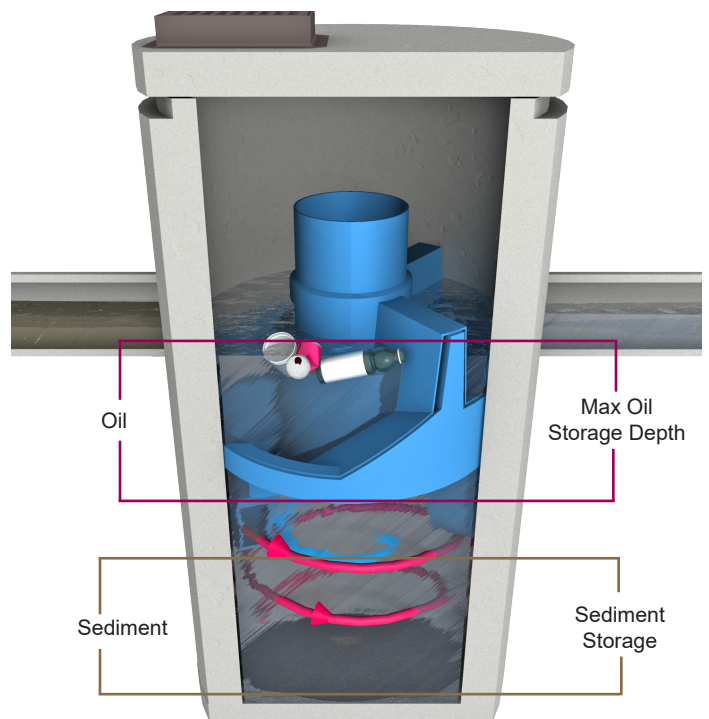

Fig.1 Pollutant storage volumes in the First Defense®.

II. Model Sizes & Configurations

The First Defense® inlet and internal bypass arrangements are available in several model sizes and configurations. The components have modified geometries allowing greater design flexibility to accommodate various site constraints.

All First Defense® models include the internal components that are designed to remove and retain total suspended solids (TSS), gross solids, floatable trash and hydrocarbons (Fig.2). First Defense® model sizes (diameter) are shown in Table 1.

III. Maintenance

First Defense® Components

- 1. Built-In Bypass
- 2. Inlet Pipe
- 3. Inlet Chute
- 4. Floatables Draw-off Port
- 5. Outlet Pipe
- 6. Floatables Storage
- 7. Sediment Storage
- 8. Inlet Grate or Cover

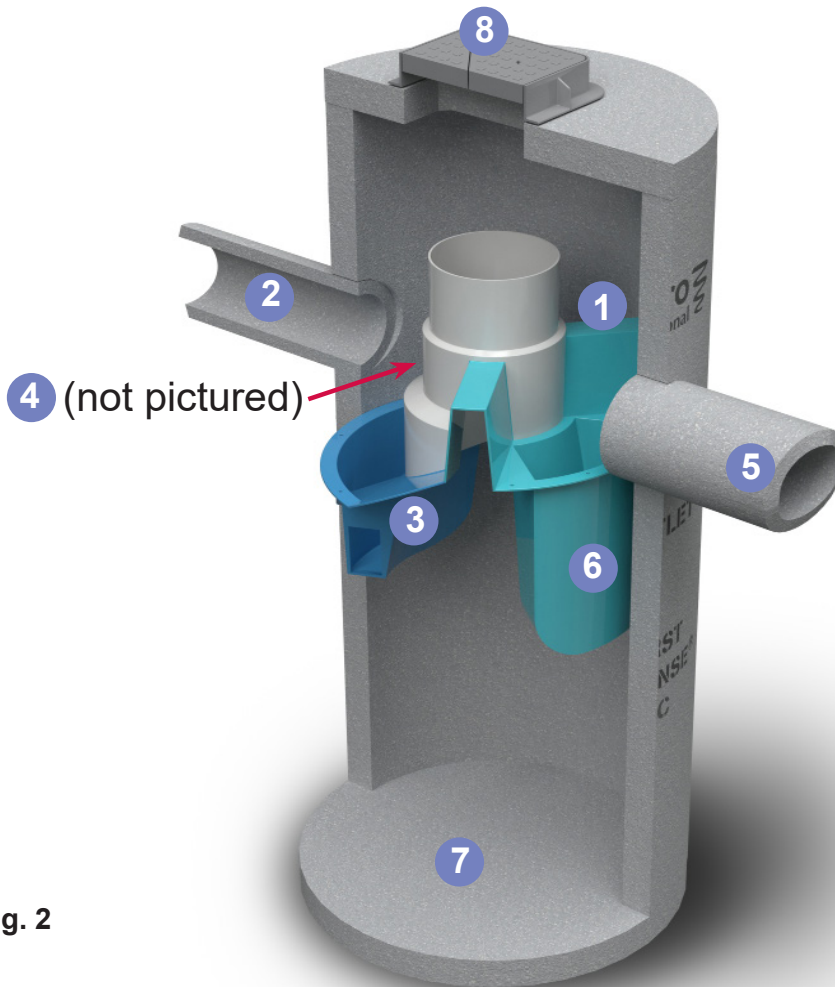

Fig. 2

Table 1

First Defense® Model Sizes
(ft / m) diameter
3 / 0.9
4 / 1.2
5 / 1.5
6 / 1.8
7 / 2.1
8 / 2.4
10 / 3.0

Overview

The First Defense® protects the environment by removing a wide range of pollutants from stormwater runoff. Periodic removal of these captured pollutants is essential to the continuous, long-term functioning of the First Defense®. The First Defense® will capture and retain sediment and oil until the sediment and oil storage volumes are full to capacity. When sediment and oil storage capacities are reached, the First Defense® will no longer be able to store removed sediment and oil.

The First Defense® allows for easy and safe inspection, monitoring and clean-out procedures. A commercially or municipally owned sump-vac is used to remove captured sediment and floatables. Access ports are located in the top of the manhole.

Maintenance events may include Inspection, Oil & Floatables Removal, and Sediment Removal. Maintenance events do not require entry into the First Defense®, nor do they require the internal components of the First Defense® to be removed. In the case of inspection and floatables removal, a vactor truck is not required. However, a vactor truck is required if the maintenance event is to include oil removal and/or sediment removal.

Maintenance Equipment Considerations

The internal components of the First Defense® have a centrally located circular shaft through which the sediment storage sump can be accessed with a sump vac hose. The open diameter of this access shaft is 15 inches in diameter (Fig.3). Therefore, the nozzle fitting of any vactor hose used for maintenance should be less than 15 inches in diameter.

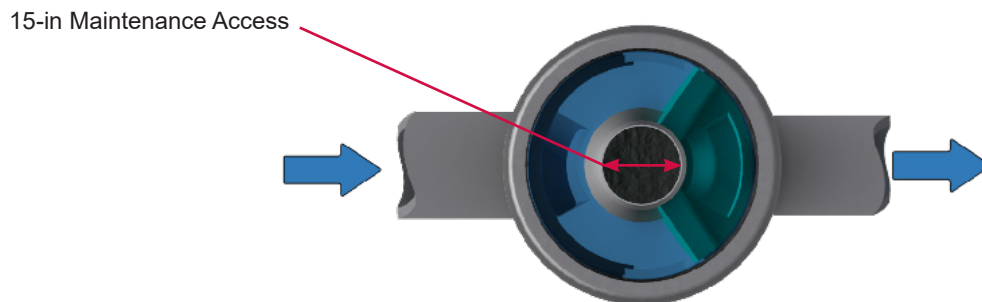

Fig.3 The central opening to the sump of the First Defense® is 15 inches in diameter.

Determining Your Maintenance Schedule

The frequency of clean out is determined in the field after installation. During the first year of operation, the unit should be inspected every six months to determine the rate of sediment and floatables accumulation. A simple probe such as a Sludge-Judge® can be used to determine the level of accumulated solids stored in the sump. This information can be recorded in the maintenance log (see page 9) to establish a routine maintenance schedule.

The vactor procedure, including both sediment and oil / floatables removal, for First Defense® typically takes less than 30 minutes and removes a combined water/oil volume of about 765 gallons.

Inspection Procedures

1. Set up any necessary safety equipment around the access port or grate of the First Defense® as stipulated by local ordinances. Safety equipment should notify passing pedestrian and road traffic that work is being done.
2. Remove the grate or lid to the manhole.
3. Without entering the vessel, look down into the chamber to inspect the inside. Make note of any irregularities. Fig.4 shows the standing water level that should be observed.
4. Without entering the vessel, use the pole with the skimmer net to remove floatables and loose debris from the components and water surface.
5. Using a sediment probe such as a Sludge Judge®, measure the depth of sediment that has collected in the sump of the vessel.
6. On the Maintenance Log (see page 9), record the date, unit location, estimated volume of floatables and gross debris removed, and the depth of sediment measured. Also note any apparent irregularities such as damaged components or blockages.
7. Securely replace the grate or lid.
8. Take down safety equipment.
9. Notify Hydro International of any irregularities noted during inspection.

Floatables and Sediment Clean Out

Floatables clean out is typically done in conjunction with sediment removal. A commercially or municipally owned sump-vac is used to remove captured sediment and floatables (Fig.4).

Floatables and loose debris can also be netted with a skimmer and pole. The access port located at the top of the manhole provides unobstructed access for a vactor hose to be lowered to the base of the sump.

Scheduling

- Floatables and sump clean out are typically conducted once a year during any season.
- Floatables and sump clean out should occur as soon as possible following a spill in the contributing drainage area.



Fig.4 Floatables are removed with a vactor hose

Recommended Equipment

- Safety Equipment (traffic cones, etc)
- Crow bar or other tool to remove grate or lid
- Pole with skimmer or net (if only floatables are being removed)
- Sediment probe (such as a Sludge Judge®)
- Vactor truck (flexible hose recommended)
- First Defense® Maintenance Log

Floatables and Sediment Clean Out Procedures

1. Set up any necessary safety equipment around the access port or grate of the First Defense® as stipulated by local ordinances. Safety equipment should notify passing pedestrian and road traffic that work is being done.
2. Remove the grate or lid to the manhole.
3. Without entering the vessel, look down into the chamber to inspect the inside. Make note of any irregularities.
4. Remove oil and floatables stored on the surface of the water with the vacator hose or with the skimmer or net
5. Using a sediment probe such as a Sludge Judge®, measure the depth of sediment that has collected in the sump of the vessel and record it in the Maintenance Log (page 9).
6. Once all floatables have been removed, drop the vacator hose to the base of the sump. Vacator out the sediment and gross debris off the sump floor
7. Retract the vacator hose from the vessel.
8. On the Maintenance Log provided by Hydro International, record the date, unit location, estimated volume of floatables and gross debris removed, and the depth of sediment measured. Also note any apparent irregularities such as damaged components, blockages, or irregularly high or low water levels.
9. Securely replace the grate or lid.

Maintenance at a Glance

Inspection	<ul style="list-style-type: none"> - Regularly during first year of installation - Every 6 months after the first year of installation
Oil and Floatables Removal	<ul style="list-style-type: none"> - Once per year, with sediment removal - Following a spill in the drainage area
Sediment Removal	<ul style="list-style-type: none"> - Once per year or as needed - Following a spill in the drainage area

NOTE: For most clean outs the entire volume of liquid does not need to be removed from the manhole. Only remove the first few inches of oils and floatables from the water surface to reduce the total volume of liquid removed during a clean out.



First Defense® Installation Log

HYDRO INTERNATIONAL REFERENCE NUMBER:	
SITE NAME:	
SITE LOCATION:	
OWNER:	CONTRACTOR:
CONTACT NAME:	CONTACT NAME:
COMPANY NAME:	COMPANY NAME:
ADDRESS:	ADDRESS:
TELEPHONE:	TELEPHONE:
FAX:	FAX:

INSTALLATION DATE: / /

MODEL SIZE (CIRCLE ONE): [3-FT] [4-FT] [5-FT] [6-FT] [7-FT] [8-FT] [10-FT]

INLET (CIRCLE ALL THAT APPLY): GRATED INLET (CATCH BASIN) INLET PIPE (FLOW THROUGH)



First Defense[®] Inspection and Maintenance Log

Date	Initials	Depth of Floatables and Oils	Sediment Depth Measured	Volume of Sediment Removed	Site Activity and Comments



Stormwater Solutions

94 Hutchins Drive
Portland, ME 04102

Tel: (207) 756-6200

Fax: (207) 756-6212

stormwaterinquiry@hydro-int.com

www.hydro-int.com