

# **NJCAT TECHNOLOGY VERIFICATION**

## **Barracuda<sup>TM</sup> MAX Hydrodynamic Separator**

**Advanced Drainage Systems, Inc.**

**April 2021**

## Table of Contents

Table of Contents.....	i
List of Figures.....	ii
List of Tables.....	iii
1. Description of Technology.....	1
2. Laboratory Testing.....	2
2.1 Test Setup.....	2
2.2 Test Sediment.....	4
2.3 Removal Efficiency Testing .....	7
2.4 Scour Testing.....	9
3. Performance Claims.....	9
4. Supporting Documentation.....	10
4.1 Removal Efficiency Results.....	10
4.2 Scour Test Results.....	22
4.3 Hydraulics.....	24
5. Design Limitations.....	25
6. Maintenance Plans.....	27
7. Statements.....	28
8. References.....	35
Verification Appendix.....	36

## **List of Figures**

Figure 1A Profile View of the Barracuda MAX S4 Model Test Unit.....	1
Figure 1B Plan View of the Barracuda MAX S4 Model Test Unit.....	1
Figure 2 Diagram of the Barracuda MAX Test Facility.....	3
Figure 3 Barracuda MAX Test Unit Effluent Sampling Area, Sediment Dosing Port, and Background Sampling Area.....	4
Figure 4 Removal Efficiency Test Sediment PSD vs. HDS Protocol Specification....	5
Figure 5 Scour Test Sediment PSD vs. HDS Protocol Specification.....	6
Figure 6 Removal Efficiency vs. Flow Rate.....	11

## List of Tables

Table 1 Particle Size Distribution of Removal Efficiency Test Sediment.....	5
Table 2 Particle Size Distribution of Scour Test Sediment.....	6
Table 3 Example Sampling Schedule (100% MTFR Run).....	8
Table 4 Summary of Removal Efficiency Results.....	12
Table 5A Summary of QA/QC Removal Efficiency Results for Flow Rate and Water Temperature.....	12
Table 5B Summary of QA/QC Removal Efficiency Results for Influent and Background Concentrations.....	12
Table 6 Barracuda MAX Summary of Removal Efficiency for 25% MTFR.....	13
Table 7 Barracuda MAX Effluent and Background TSS for 25% MTFR.....	13
Table 8A Barracuda MAX Doser Sample Data for 25% MTFR.....	14
Table 8B Barracuda MAX Influent Concentration for 25% MTFR.....	14
Table 9 Barracuda MAX Summary of Removal Efficiency for 50% MTFR.....	15
Table 10 Barracuda MAX Effluent and Background TSS for 50% MTFR.....	15
Table 11A Barracuda MAX Doser Sample Data for 50% MTFR.....	16
Table 11B Barracuda MAX Influent Concentration for 50% MTFR.....	16
Table 12 Barracuda MAX Summary of Removal Efficiency for 75% MTFR.....	17
Table 13 Barracuda MAX Effluent and Background TSS for 75% MTFR.....	17
Table 14A Barracuda MAX Doser Sample Data for 75% MTFR.....	18
Table 14B Barracuda MAX Influent Concentration for 75% MTFR.....	18
Table 15 Barracuda MAX Summary of Removal Efficiency for 100% MTFR.....	19
Table 16 Barracuda MAX Effluent and Background TSS for 100% MTFR.....	19

Table 17A Barracuda MAX Doser Sample Data for 100% MTFR.....	20
Table17B Barracuda MAX Influent Concentration for 100% MTFR.....	20
Table 18 Barracuda MAX Summary of Removal Efficiency for 125% MTFR.....	21
Table 19 Barracuda MAX Effluent and Background TSS for 125% MTFR.....	21
Table 20A Barracuda MAX Doser Sample Data for 125% MTFR.....	22
Table20B Barracuda MAX Influent Concentration for 125% MTFR.....	22
Table 21 QA/QC Results for Scour Run.....	23
Table 22 Background and Effluent TSS Concentrations for Scour Run.....	23
Table 23 Recorded Flow and Head Elevation.....	24
Table A-1 MTFRs and Sediment Removal Intervals for Barracuda™ MAX Models....	38
Table A-2 Standard Dimensions for Barracuda™ MAX Models.....	39

## 1. Description of Technology

Advanced Drainage Systems' (ADS) Barracuda™ MAX Hydrodynamic Separator (Barracuda MAX), presented in **Figure 1A** and **Figure 1B**, is a stormwater treatment device that removes suspended solids from stormwater. Stormwater is directed to a cone-shaped (vortex) device inside the unit, while the water resides in the pool of the cone. A weir prevents inflowing water from bypassing the vortex separator until the head reaches the bypass elevation. Once water has flowed through the vortex and a majority of the sediment has settled out into the sump, the effluent water rises up to the effluent pipe. The “fins” affixed to the inside walls of the test unit reduce the velocity of water in the vortex flow pattern below the cone and effectively reduce re-suspension of sediment in the sump, allowing the accumulated sediment to remain within the unit. The “deflector plate” and “center drop-down tube” further enhance the removal capability of the system.

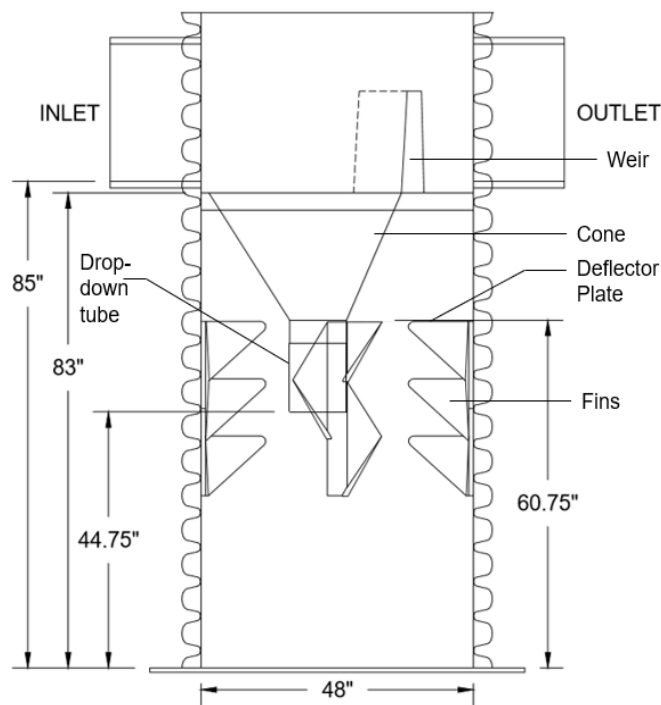

**Figure 1A Profile View of the Barracuda MAX S4 Model Test Unit**

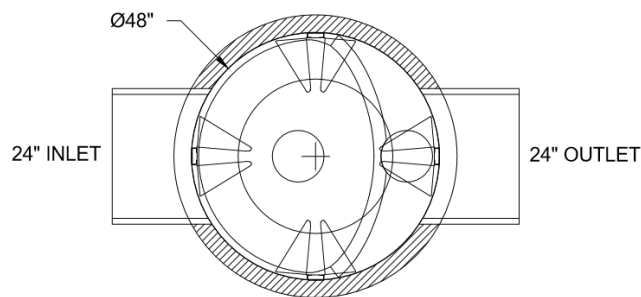

**Figure 1B Plan View of the Barracuda MAX S4 Model Test Unit**

## 2. Laboratory Testing

All testing disclosed in this report was performed in accordance with the New Jersey Department of Environmental Protection (NJDEP) Laboratory Protocol to Assess Total Suspended Solids Removal by a Hydrodynamic Sedimentation Manufactured Treatment Device (NJDEP Protocol) dated January 25, 2013. The NJDEP approval process requires submittal of a Quality Assurance Project Plan (QAPP) to the New Jersey Corporation for Advanced Technology (NJCAT) for review and approval prior to testing to ensure that all laboratory procedures will be conducted in strict accordance with the NJDEP Protocol. The QAPP was submitted and approved by NJCAT in October 2020, prior to commencement of testing.

All removal efficiency and scour testing for this project was carried out at ADS's BaySaver Laboratory in Mount Airy, MD, in December 2020. Independent third-party observation was provided by Robert J. Warfel, Boggs Environmental Consultants, Inc. (BEC) in accordance with the NJDEP Protocol. BEC is an independent environmental and engineering consulting company located in Middletown, Maryland. All water quality samples collected during the test program were analyzed by Fredericktowne Labs, which is an independent environmental testing laboratory. All sediment PSD samples were analyzed by ECS Mid-Atlantic, LLC, which is an independent geotechnical and environmental testing facility.

### 2.1 Test Setup

The test unit was a full-scale commercially available Barracuda™ MAX S4 Model Hydrodynamic Separator (Barracuda MAX) consisting of a vortex separator, sedimentation sump, fins, deflector plate, and center drop-down tube. The unit measured at approximately 121 inches in height and 48 inches in diameter. Influent and effluent piping to the unit were 24 inches in diameter and at approximately the same inlet/outlet elevations. The total sedimentation area of this unit was 12.57 ft<sup>2</sup>. Each Barracuda MAX model has a 20-inch deep sediment sump.

The water source was municipal tap water added to the test system via hoses at the various water source tanks before the start of testing. As shown below in **Figure 2**, this feed water was stored in the supply tanks and then pumped to the feed basin for each test run. A PVC flow system with multiple pumps of various capacities (Godwin 8-hp, Godwin 4-hp, and WB30XT, etc.) was used to pump tap water from the various supply tanks to the feed basin, as needed to meet the target flow rates for each individual run. The Flygt pump fed water from the feed basin to the influent pipe, and a throttling valve was used to achieve all testing flow rates in this study. The flow rates were measured using a FloCat MFE electromagnetic flow meter and recorded at one-minute intervals by a SeaMetrics DL76 data logger. As required by the NJDEP Protocol, the temperature of the feed water was less than 80° Fahrenheit during all testing and was measured and recorded in one-minute intervals by a HOBO data logger located inside the feed basin.

The feed water was pumped from the feed basin to the separator inlet. Test sediment was dry fed by a volumetric screw feeder through a 12-inch port at the crown of the 24-inch diameter influent pipe at a distance 8 feet upstream of the test unit (indicated by the **Letter B in Figure 2**). The influent water entered the test unit, was treated by the Barracuda MAX, exited via the effluent

pipe, and was discharged into the Effluent Discharge Tank (indicated by **Letter C in Figure 2, and photograph in Figure 3**).

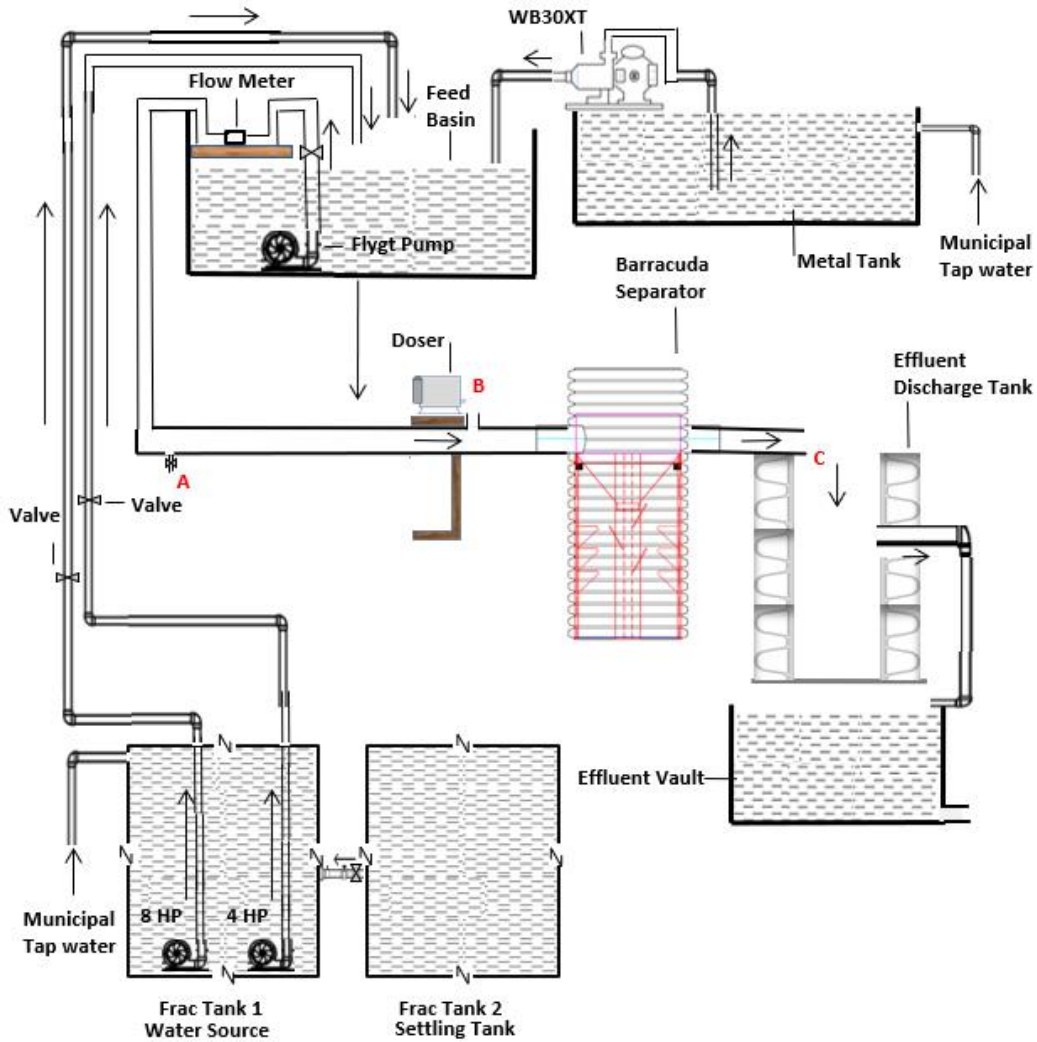

**Figure 2 Diagram of the Barracuda MAX Test Facility**

Influent sediment feed sample collection occurred at the influent sediment port (**Letter B in Figure 2 and photograph in Figure 3**); effluent water sample collection occurred at the Barracuda MAX effluent pipe (**Letter C in Figure 2 and photograph in Figure 3**). Background sample collection (**Letter A in Figure 2 and photograph in Figure 3**) occurred upstream of the sediment injection port. Background and effluent sample volumes were a minimum of 500 ml.





**Figure 3 Barracuda MAX Test Unit Effluent Sampling Area, Sediment Dosing Port, and Background Sampling Area**

## **2.2 Test Sediment**

The test sediment used for removal efficiency testing was a blend of high purity commercially available silica sand. The test sediment was batched, labeled, and stored in five covered bins for the duration of this project. Under the supervision of BEC, twenty subsamples, taken from various locations within the test sediment containers, were composited, and then three random samples collected from the composite sample were sent to ECS Mid-Atlantic, LLC, for PSD analysis using method ASTM D422-63. The results of the PSD analysis are presented in **Table 1** and **Figure 4**. The test sediment used for removal efficiency testing was verified to be in compliance with the NJDEP HDS Protocol specification. The  $d_{50}$  of the sediment was found to be 65  $\mu\text{m}$  (microns) and the sediment was finer than that required by the protocol, thus acceptable for use. Additionally, the average moisture content of the test sediment was determined by ECS to be 0.067%.

The test sediment used for scour testing was a blend of high purity commercially available silica sand. The test sediment was batched, labeled, and stored in seven covered bins for the duration of this project. Under the supervision of BEC, twenty-eight subsamples, taken from various locations within the test sediment containers, were composited, and then three random samples collected from the composite sample were sent to ECS Mid-Atlantic, LLC, for PSD analysis using method ASTM D422-63. The results of the PSD analysis are presented in **Table 2** and **Figure 5**. The test sediment used for removal efficiency testing was verified to be in compliance with the NJDEP HDS Protocol specification. The sediment was finer than that required by the protocol, thus acceptable for use.

**Table 1 Particle Size Distribution of Removal Efficiency Test Sediment**

Particle Size ( $\mu\text{m}$ )	Test Blend % Finer by Mass Analyzed by ECS				NJDEP Specification (minimum % passing)
	NJ Blend A	NJ Blend B	NJ Blend C	Average	
1000	100.0	100.0	100.0	100	98
500	94.5	94.5	94.0	94.3	93
250	89.9	90.1	89.9	90.0	88
150	76.8	74.2	77.4	76.1	73
100	59.2	57.5	59.1	58.6	58
75	51.1	50.8	50.8	50.9	50
50	48.1	48.1	48.2	48.1	43
20	37.1	37.3	37.5	37.3	33
8	19.4	20.2	20.5	20.0	18
5	13.5	13.5	14.2	13.7	8
2	7.1	7.1	7.1	7.1	3

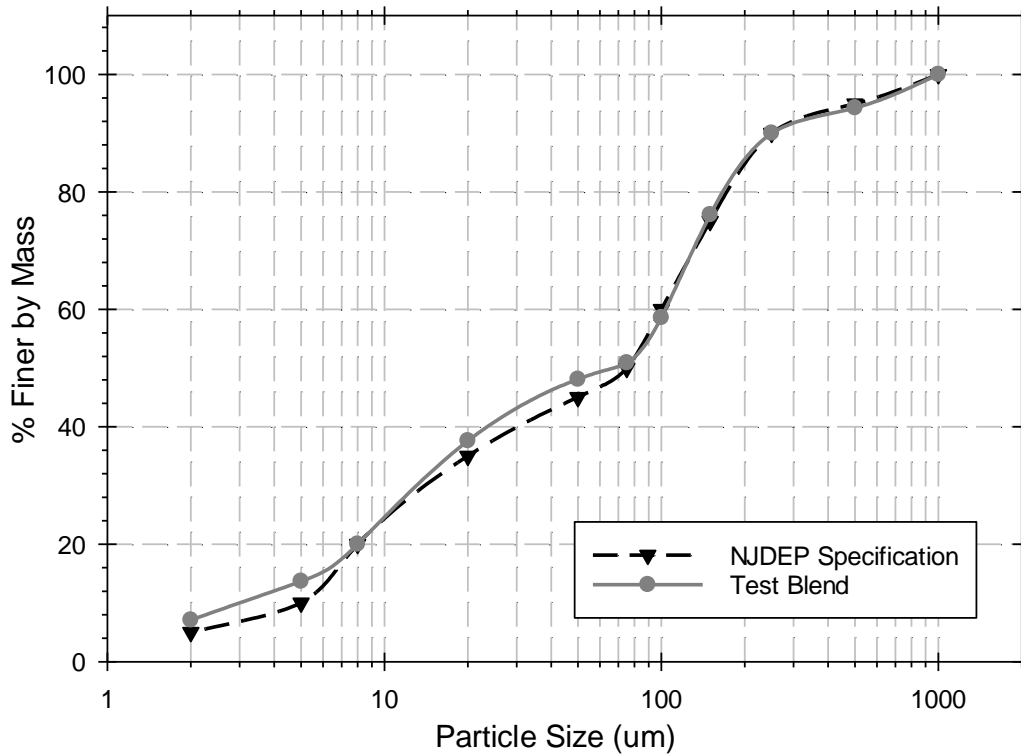

**Figure 4 Removal Efficiency Test Sediment PSD vs. HDS Protocol Specification**

**Table 2 Particle Size Distribution of Scour Test Sediment**

Particle Size ( $\mu\text{m}$ )	Test Blend % Finer by Mass Analyzed by ECS				
	<u>NJ Blend A</u>	<u>NJ Blend B</u>	<u>NJ Blend C</u>	<u>Average</u>	<u>NJDEP Specification (minimum % passing)</u>
1000	100.0	100.0	100.0	100.0	98.0
500	88.0	89.0	88.1	88.4	88.0
250	61.4	62.3	61.4	61.7	53.0
150	44.3	47.4	49.4	47.0	38.0
100	22.2	24.0	30.0	25.4	23.0
75	9.2	11.9	15.0	12.0	8.0
50	4.2	5.2	5.2	4.9	0

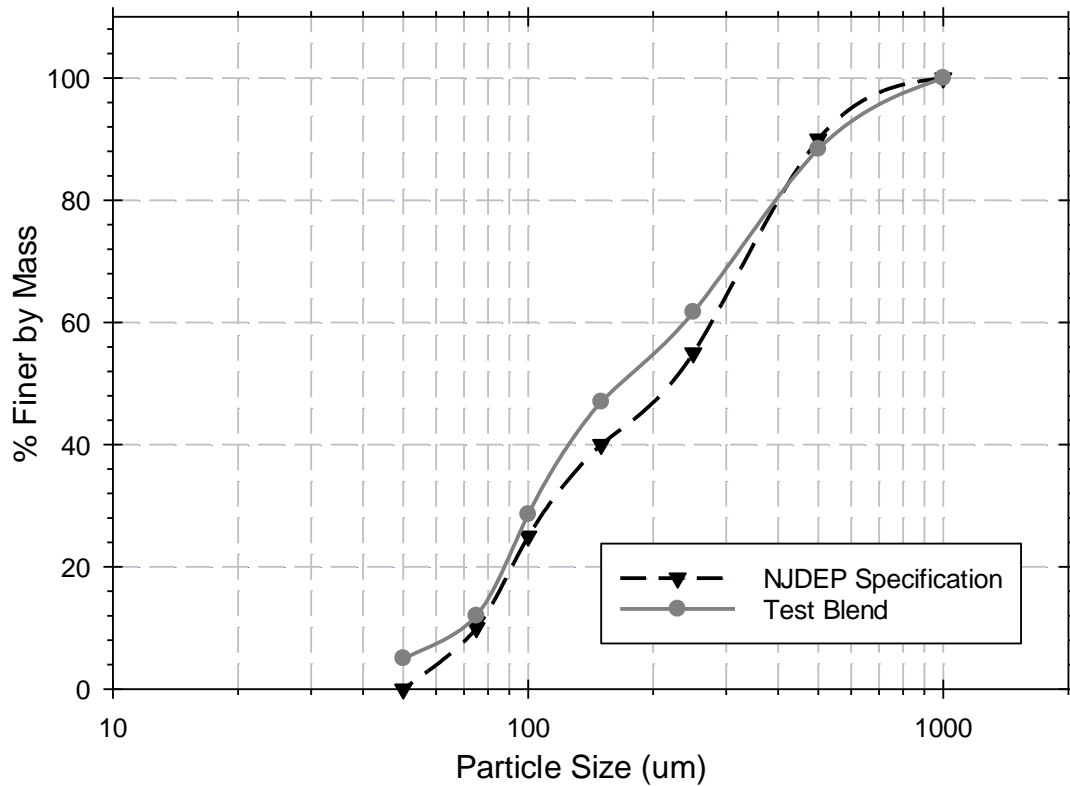

**Figure 5 Scour Test Sediment PSD vs. HDS Protocol Specification**

### 2.3 Removal Efficiency Testing

Removal efficiency testing was conducted in accordance with Section 5 of the NJDEP Laboratory Protocol for HDS MTDs. A false floor was installed in the unit at the 50% sediment storage depth of 10-inches above the device floor. Testing was conducted at five flow rates: 25%, 50%, 75%, 100%, and 125% of the Barracuda MAX S4 Maximum Treatment Flow Rate (MTFR) of 1.52 cfs, and at a target influent sediment concentration of 200 mg/L.

The flow rate, measured using a manufacturer-calibrated FloCat MFE flow meter and recorded once per minute using a Seametrics DL76 data logger, was held steady during each test at  $\pm 10\%$  of the target value with a coefficient of variation (COV) less than the allowed 0.03. Water temperature remained below 80 °F during all testing.

Test sediment was introduced to the flow stream via a volumetric screw auger to produce a target average influent concentration of 200 mg/L ( $\pm 10\%$ ) with a COV of less than the allowed 0.10. Each sediment sample was collected in a 1000 ml plastic container over an interval timed to the nearest tenth of a second using a Sportline P176 stopwatch, for a sample volume of 100 ml or a collection time of one minute (whichever came first). Sediment feed samples were weighed to the nearest mg on a Cole-Parmer Symmetry PR410 analytical balance (under the supervision of BEC).

The total mass introduced was determined by measuring the mass of sediment added to the doser prior to testing, subtracting the amount of sediment remaining in the doser at the end of the run, and subtracting the mass of the sediment feed samples taken during the run. The average influent TSS concentration for each run was calculated using the total measured mass of the test sediment added during dosing divided by the total volume of water that flowed through the unit during dosing as described by Equation 1.

#### Equation 1:

$$\text{Average Influent Concentration} = \frac{\text{Total mass added}}{\text{Total volume of water flowing through the MTD during addition of test sediment}}$$

Effluent samples were collected in clean, 1 L bottles by sweeping the bottle through the cross-section of the free-discharge effluent stream in a single pass. The first effluent grab sample was collected following a minimum of three MTD detention times after flow rate was established and the first sediment sample was collected. Sequential effluent samples were collected every 30 seconds. When sediment feed was interrupted for measurement, the next series of sequential effluent samples were collected after three MTD detention times had passed. Fifteen effluent samples were collected during each flow test run, and eight background samples were collected in correspondence with the odd-numbered effluent samples. An example sampling schedule (for 100% MTFR) is given in **Table 3**.

All effluent and background water samples were sent to Fredericktowne Labs and analyzed using ASTM D3977-97 (Re-approval 2019) for TSS (measured as SSC) to determine the sediment concentration. Average background concentration did not exceed 20 mg/L during any test. In cases where TSS was reported as non-detect for a background sample, a value of half the reported detection limit was substituted. The TSS for each effluent sample was corrected by the corresponding background sample's TSS.

Removal efficiency was calculated using **Equation 2**.

**Equation 2:**

$$\text{Removal Efficiency (\%)} = \frac{\left( \text{Average Influent Concentration} - \frac{\text{Adjusted Average Effluent* Concentration}}{\text{Average Influent Concentration}} \right)}{\text{Average Influent Concentration}} \times 100$$

\* Adjusted for background concentration

**Table 3 Example Sampling Schedule (100% MTFR Run)**

Elapsed Time (min)	Effluent Sample	Background Sample	Dry Feed Sample
0.0			0
3.5	1	1	
4.0	2		
4.5	3	3	1
8.0	4		
8.5	5	5	
9.0	6		2
12.5	7	7	
13.0	8		
13.5	9	9	3
17.0	10		
17.5	11	11	
18.0	12		4
21.5	13	13	
22.0	14		
22.5	15	15	5

## 2.4 Scour Testing

The Barracuda MAX was tested under online installation conditions following the procedure described in Section 4 of the NJDEP Protocol. Under supervision of BEC, the false floor was adjusted to 4 in. below the 50% sediment storage capacity 10-inch height (6 in. above the floor of the unit) and pre-loaded with 4 in. of leveled scour test sediment. The unit was filled with municipal tap water to its normal, dry weather operating depth, and testing commenced within 96 hrs.

Scour testing began by slowly introducing flow and, in less than 5 minutes, ramping up the flow rate until it reached >200% of the MTFR (> 3.04 cfs). The flow rate was recorded every minute. For the duration of the test, the flow rate was held steady at  $\pm 10\%$  of the target flow rate with a COV less than the allowed 0.03. Water temperature remained below 80 °F during the test.

Effluent samples were collected utilizing the Effluent Grab Sampling Method, and time stamped every two minutes after achieving the maximum target flow rate. A total of 15 effluent samples (500 mL minimum) were taken over the duration of the test. Eight background samples were collected at evenly time-spaced intervals throughout the duration of the scour testing, timed corresponding to the odd-numbered effluent samples.

All water samples collected (background and effluent) were analyzed by Fredericktowne Labs for TSS according to ASTM D3977-97 (Re-approval 2019) “Standard Test Methods for Determining Sediment Concentrations in Water Samples.” All background concentrations were less than 20 mg/L. All effluent sample results from the scour test run were adjusted by subtracting the paired background from the recorded effluent sample. In cases where the TSS concentration was reported as non-detect, a value of half the reported detection limit was substituted.

## 3. Performance Claims

Per the NJDEP verification procedure and based on the laboratory testing conducted for the Barracuda™ MAX S4 Model (Barracuda MAX), the following are the performance claims made by Advanced Drainage Systems.

### *Total Suspended Solids (TSS) Removal Efficiency*

For the particle size distribution and weighted calculation method required by the 2013 NJDEP HDS Protocol, the Barracuda MAX achieved a weighted TSS removal efficiency of at least 50% for an MTFR of 1.52 cfs.

### *Maximum Treatment Flow Rate (MTFR)*

The MTFR for the Barracuda MAX (S4 model) was demonstrated to be 1.52 cfs (682 gpm) with a total sedimentation area of 12.57 ft<sup>2</sup>, which corresponds to a surface loading rate of 54.2 gpm/ft<sup>2</sup> of sedimentation area.

### *Maximum Sediment Storage Depth and Volume*

The maximum sediment storage depth is 20 inches, which corresponds to 20.94 ft<sup>3</sup> of sediment storage volume for the Barracuda MAX S4 model. A sediment storage depth of 10 inches corresponds to 50% full sediment storage capacity (10.47 ft<sup>3</sup>).

### *Effective Treatment and Sedimentation Area*

The effective treatment and sedimentation area of the Barracuda MAX varies with model size, as it is dependent upon the surface area of the model, which varies with diameter. The effective treatment and sedimentation area of the Barracuda MAX S4 model is 12.57 ft<sup>2</sup>.

### *Detention Time and Volume*

The Barracuda MAX detention time depends on flow rate and model size. The Barracuda MAX model tested (S4) had a detention time of approximately 52 seconds for a flow rate of 1.52 cfs (682 gpm). Detention time is calculated by dividing the treatment chamber wet volume by the MTRF. The wet volume is defined as the volume between the pipe invert and the false floor. However, since the operating water volume in the Barracuda MAX increases as flow increases during testing, the 3X detention time was calculated up to the crest of the weir for all runs. That detention time is 60 seconds. Bypass in the Barracuda MAX S4 occurred at 1.63 cfs (732 gpm).

### *On-line Installation*

Based on the results of the scour testing, the Barracuda MAX qualifies for on-line installation.

## **4. Supporting Documentation**

The NJDEP Procedure (NJDEP, 2013) for obtaining verification of a stormwater manufactured treatment device (MTD) from the New Jersey Corporation for Advanced Technology (NJCAT) requires that “copies of the laboratory test reports, including all collected and measured data; all data from performance evaluation test runs; spreadsheets containing original data from all performance test runs; all pertinent calculations; etc.” be included in this section. This was discussed with NJDEP and it was agreed that as long as such documentation could be made available by NJCAT upon request that it would not be prudent or necessary to include all this information in this verification report. This information was provided to NJCAT and is available upon request.

### **4.1 Removal Efficiency Results**

Removal efficiency test runs were completed on the Barracuda MAX (S4 model) at flow rates of 25%, 50%, 75%, 100%, and 125% MTRF at a target average influent concentration of 200 mg/L in accordance with the NJDEP HDS protocol. The results from the five test runs were used to calculate the overall annualized weighted removal efficiency.

Average flow rate was determined from the data collected from the flow data logger in one-minute intervals. A mass balance on the doser was used to calculate the average influent concentration for each run. Average influent concentration for each run was calculated by using the total mass of the test sediment added during dosing, divided by the volume of water that flowed through the MTD during dosing.

The average effluent concentration was adjusted by subtracting the measured background concentration. All background concentrations were less than the 20 mg/L maximum allowable concentration specified by the NJDEP HDS Protocol. The removal efficiency for each run was calculated using **Equation 2** above.

The annualized weighted TSS removal efficiency has been calculated using the weighting factors provided in the NJDEP HDS protocol. The Barracuda MAX achieved an annualized weighted removal efficiency of 55.5% at an MTRF of 1.52 cfs. The removal efficiency results are summarized in **Figure 6** and **Table 4**. This testing demonstrates that the Barracuda MAX exceeds the NJDEP requirement that HDS devices demonstrate at least 50% weighted annualized TSS removal efficiency at the MTRF. All tests met the NJDEP Protocol requirements and QA/QC parameters (**Tables 5A and 5B**).

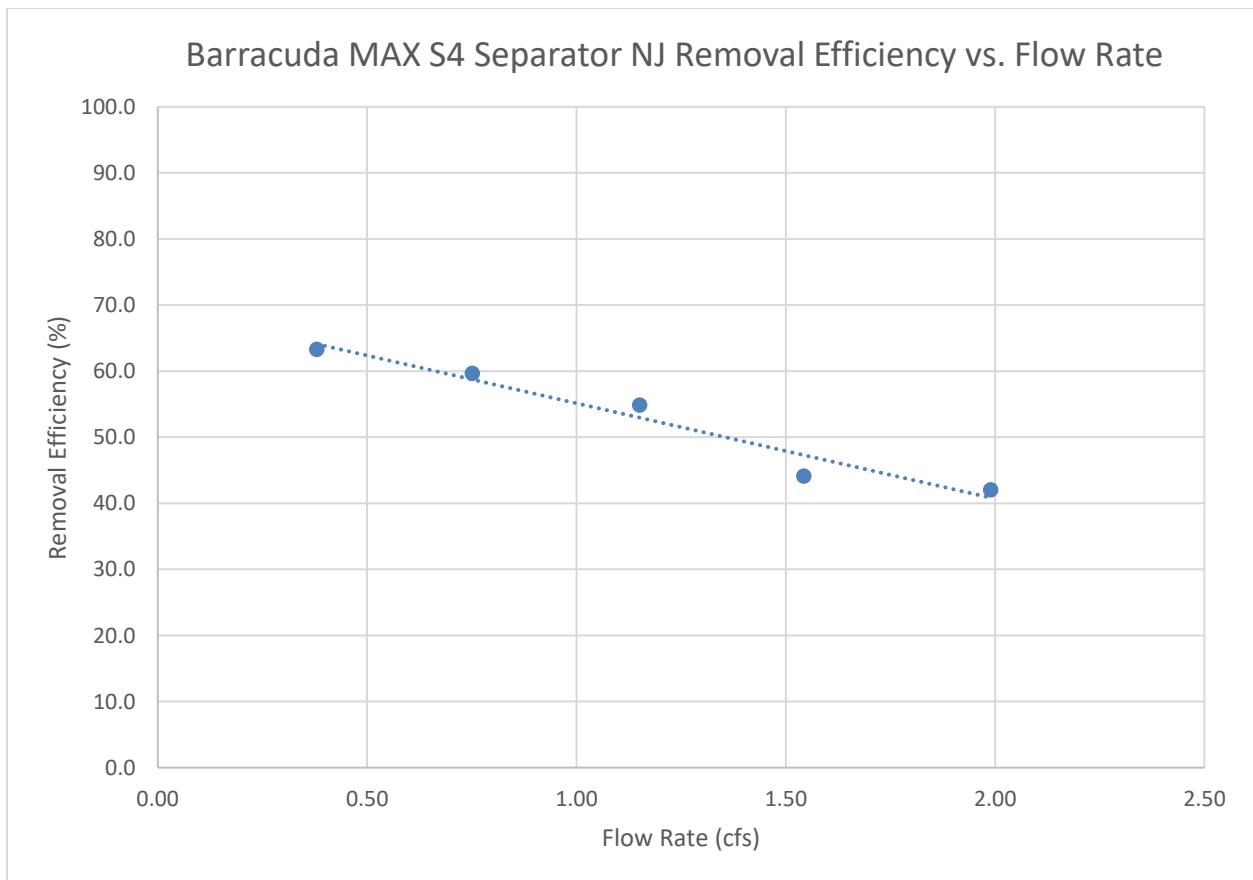

**Figure 6 Removal Efficiency vs. Flow Rate**



**Table 4 Summary of Removal Efficiency Results**

<b>% MTR</b>	<b>Target Flow Rate (cfs)</b>	<b>Average Flow Rate (cfs)</b>	<b>Average Influent Conc. (mg/L)</b>	<b>Average Adj. Effluent Conc. (mg/L)</b>	<b>Removal Efficiency (%)</b>	<b>Weighting Factor</b>	<b>Weighted Removal</b>
25	0.38	0.38	201	74	63.3	0.25	15.8
50	0.76	0.75	199	80	59.7	0.30	17.9
75	1.14	1.15	212	96	54.9	0.20	11.0
100	1.52	1.54	190	106	44.1	0.15	6.6
125	1.90	1.99	212	123	42.0	0.10	4.2
<b>Annualized Weighted Removal Efficiency at MTR of 1.52 cfs (%):</b>							<b>55.5</b>

**Table 5A Summary of QA/QC Removal Efficiency Results for Flow Rate and Water Temperature**

<b>% MTR</b>	<b>QA/QC PASS/FAIL</b>	<b>Target Flow Rate (cfs)</b>	<b>Average Flow Rate (cfs) (+/- 10%)</b>	<b>Flow Rate COV (<math>\leq 0.03</math>)</b>	<b>Maximum Water Temp. (<math>\leq 80^{\circ}</math> F)</b>
25	PASS	0.38	0.38	0.013	48.9
50	PASS	0.76	0.75	0.012	51.7
75	PASS	1.14	1.15	0.007	48.0
100	PASS	1.52	1.54	0.005	47.3
125	PASS	1.90	1.99	0.003	48.3

**Table 5B Summary of QA/QC Removal Efficiency Results for Influent and Background Concentrations**

<b>% MTR</b>	<b>QA/QC PASS/FAIL</b>	<b>Target Influent TSS Conc. (mg/L)</b>	<b>Influent TSS Conc. (mg/L) (+/- 10%)</b>	<b>Sediment Feed Rate COV (<math>\leq 0.1</math>)</b>	<b>Average Background TSS (mg/L) (<math>\leq 20</math> mg/L)</b>
25	PASS	200	201	0.075	0.5
50	PASS	200	199	0.067	0.5
75	PASS	200	212	0.023	3.0
100	PASS	200	190	0.039	3.3
125	PASS	200	212	0.056	0.6

*Removal Efficiency Test Results for 25% MTFR*

The 25% MTFR test was conducted in accordance with the NJDEP HDS Protocol at a target flow rate of 0.38 cfs. A summary of the performance results for this run is shown in **Table 6** below. Background and effluent sampling measurements are presented in **Table 7**. Doser data and influent TSS concentration results are given in **Tables 8A and 8B**. The Barracuda MAX test unit removed 63.3% of the test sediment at a flow rate of 0.38 cfs. QA/QC results for flow rate, feed rate and influent, effluent and background concentrations were within the allowable parameters specified by the protocol as shown above in **Tables 5A and 5B**.

**Table 6 Barracuda MAX Summary of Removal Efficiency for 25% MTFR**

Target Flow Rate (cfs)	Average Flow Rate (cfs)	Target Flow Rate (gpm)	Average Flow Rate (gpm)	Detention Time (min)	Run Length (min)	Max. Water Temp. (°F)	Influent Conc. (mg/L)	Adj. Effluent Conc. (mg/L)	Removal Efficiency (%)
0.38	0.38	171	170	3.4	71.5	49	201	73.6	63.3

**Table 7 Barracuda MAX Effluent and Background TSS for 25% MTFR**

Sample ID	Run Time (min)	Effluent TSS (mg/L)	Background TSS (mg/L)	Reporting Limit (mg/L)	Background TSS Used in Calc. (mg/L)	Adjusted Effluent TSS (mg/L)
1	13	67	ND	1.0	0.5	66.5
2	13.5	75			0.5	74.5
3	14	71	ND	1.0	0.5	70.5
4	27	75			0.5	74.5
5	27.5	73	ND	1.0	0.5	72.5
6	28	75			0.5	74.5
7	41	86	ND	1.0	0.5	85.5
8	41.5	87			0.5	86.5
9	42	82	ND	1.0	0.5	81.5
10	55	87			0.5	86.5
11	55.5	70	ND	1.0	0.5	69.5
12	56	72			0.5	71.5
13	69	61	ND	1.0	0.5	60.5
14	69.5	65			0.5	64.5
15	70	66	ND	1.0	0.5	65.5
Average						73.6

*\*Shaded background concentrations are interpolated.*

**Table 8A Barracuda MAX Doser Sample Data for 25% MTFR**

Sample ID	Time into Run (min)	Sample Mass (g)	Sample Duration (s)	Sediment Feed Rate (g/min)	Calculated Influent TSS (mg/L)
0	0	124.03	53.31	139.6	217
1	14	107.48	53.31	121.0	188
2	28	103.42	53.34	116.3	181
3	42	118.87	53.38	133.6	207
4	56	121.30	53.35	136.4	212
5	70	122.48	53.16	138.2	215
				Mean	130.9

**Table 8B Barracuda MAX Influent Concentration for 25% MTFR**

Dosed Sediment Mass (g)	Dosing Duration (min)	Adjusted Influent Water (gallons)	Calc. Influent Feed TSS* (mg/L)
8807	68.11	11597	200.6

*\*Average influent concentration reported was calculated by dividing the entire mass of test sediment injected into the flow stream over the duration of the test by the total flow volume during the injection of test sediment.*

*Removal Efficiency Test Results for 50% MTFR*

The 50% MTFR test was conducted in accordance with the NJDEP HDS Protocol at a target flow rate of 0.76 cfs. A summary of the performance results for this run is shown in **Table 9** below. Background and effluent sampling measurements are presented in **Table 10**. Doser data and influent TSS concentration results are given in **Tables 11A and 11B**. The Barracuda MAX test unit removed 59.7% of the test sediment at a flow rate of 0.75 cfs. QA/QC results for flow rate, feed rate and influent, effluent and background concentrations were within the allowable parameters specified by the protocol as shown above in **Tables 5A and 5B**.

**Table 9 Barracuda MAX Summary of Removal Efficiency for 50% MTR**

Target Flow Rate (cfs)	Average Flow Rate (cfs)	Target Flow Rate (gpm)	Average Flow Rate (gpm)	Detention Time (min)	Run Length (min)	Max. Water Temp. (°F)	Influent Conc. (mg/L)	Adj. Effluent Conc. (mg/L)	Removal Efficiency (%)
0.76	0.75	341	337	1.7	39	52	199	80.2	59.7

**Table 10 Barracuda MAX Effluent and Background TSS for 50% MTR**

Sample ID	Run Time (min)	Effluent TSS (mg/L)	Background TSS (mg/L)	Reporting Limit (mg/L)	Background TSS Used in Calc. (mg/L)	Adjusted Effluent TSS (mg/L)
1	6.5	82	ND	1.0	0.5	81.5
2	7	78			0.5	77.5
3	7.5	81	ND	1.0	0.5	80.5
4	14	74			0.5	73.5
5	14.5	80	ND	1.0	0.5	79.5
6	15	77			0.5	76.5
7	21.5	81	ND	1.0	0.5	80.5
8	22	76			0.5	75.5
9	22.5	79	ND	1.0	0.5	78.5
10	29	84			0.5	83.5
11	29.5	85	ND	1.0	0.5	84.5
12	30	83			0.5	82.5
13	36.5	86	ND	1.0	0.5	85.5
14	37	81			0.5	80.5
15	37.5	83	ND	1.0	0.5	82.5
Average						80.2

*\*Shaded background concentrations are interpolated.*

**Table 11A Barracuda MAX Doser Sample Data for 50% MTFR**

Sample ID	Time into Run (min)	Sample Mass (g)	Sample Duration (s)	Sediment Feed Rate (g/min)	Calculated Influent TSS (mg/L)
0	0	112.32	26.16	257.6	202
1	7.5	101.02	26.18	231.5	182
2	15	121.73	26.10	279.8	219
3	22.5	104.35	26.22	238.8	187
4	30	110.54	26.25	252.7	198
5	37.5	113.84	26.37	259.0	203
				Mean	253.2

**Table 11B Barracuda MAX Influent Concentration for 50% MTFR**

Dosed Sediment Mass (g)	Dosing Duration (min)	Adjusted Influent Water (gallons)	Calc. Influent Feed TSS* (mg/L)
9442	37.25	12552	198.7

*\*Average influent concentration reported was calculated by dividing the entire mass of test sediment injected into the flow stream over the duration of the test by the total flow volume during the injection of test sediment.*

*Removal Efficiency Test Results for 75% MTFR*

The 75% MTFR test was conducted in accordance with the NJDEP HDS Protocol at a target flow rate of 1.14 cfs. A summary of the performance results for this run is shown in **Table 12** below. Background and effluent sampling measurements are presented in **Table 13**. Doser data and influent TSS concentration results are given in **Tables 14A and 14B**. The Barracuda MAX test unit removed 54.9% of the test sediment at a flow rate of 1.15 cfs. QA/QC results for flow rate, feed rate and influent, effluent and background concentrations were within the allowable parameters specified by the protocol as shown above in **Tables 5A and 5B**.

**Table 12 Barracuda MAX Summary of Removal Efficiency for 75% MTR**

Target Flow Rate (cfs)	Average Flow Rate (cfs)	Target Flow Rate (gpm)	Average Flow Rate (gpm)	Detention Time (min)	Run Length (min)	Max. Water Temp. (°F)	Influent Conc. (mg/L)	Adj. Effluent Conc. (mg/L)	Removal Efficiency (%)
1.14	1.15	512	517	1.2	29	48	212	95.7	54.9

**Table 13 Barracuda MAX Effluent and Background TSS for 75% MTR**

Sample ID	Run Time (min)	Effluent TSS (mg/L)	Background TSS (mg/L)	Reporting Limit Limit (mg/L)	Background TSS Used in Calc. (mg/L)	Adjusted Effluent TSS (mg/L)
1	4.5	88	2	1.0	2.0	86.0
2	5	97			1.5	95.5
3	5.5	93	1	1.0	1.0	92.0
4	10	103			2.0	101.0
5	10.5	96	3	1.0	3.0	93.0
6	11	101			4.5	96.5
7	15.5	107	6	1.0	6.0	101.0
8	16	100			5.0	95.0
9	16.5	97	4	1.0	4.0	93.0
10	21	101			4.5	96.5
11	21.5	99	5	1.0	5.0	94.0
12	22	99			3.5	95.5
13	26.5	98	2	1.0	2.0	96.0
14	27	101			1.5	99.5
15	27.5	102	1	1.0	1.0	101.0
Average						95.7

*\*Shaded background concentrations are interpolated.*

**Table 14A Barracuda MAX Doser Sample Data for 75% MTR**

Sample ID	Time into Run (min)	Sample Mass (g)	Sample Duration (s)	Sediment Feed Rate (g/min)	Calculated Influent TSS (mg/L)
0	0	118.81	18.04	395.2	202
1	5.5	124.63	18.09	413.4	211
2	11	121.77	18.00	405.9	208
3	16.5	127.68	18.10	423.3	216
4	22	122.68	18.03	408.3	209
5	27.5	121.94	18.15	403.1	206
				Mean	408.2

**Table 14B Barracuda MAX Influent Concentration for 75% MTR**

Dosed Sediment Mass (g)	Dosing Duration (min)	Adjusted Influent Water (gallons)	Calc. Influent Feed TSS* (mg/L)
11528	27.80	14361	212.1

*\*Average influent concentration reported was calculated by dividing the entire mass of test sediment injected into the flow stream over the duration of the test by the total flow volume during the injection of test sediment.*

*Removal Efficiency Test Results for 100% MTR*

The 100% MTR test was conducted in accordance with the NJDEP HDS Protocol at a target flow rate of 1.52 cfs. A summary of the performance results for this run is shown in **Table 15** below. Background and effluent sampling measurements are presented in **Table 16**. Doser data and influent TSS concentration results are given in **Tables 17A and 17B**. The Barracuda MAX test unit removed 44.1% of the test sediment at a flow rate of 1.54 cfs. QA/QC results for flow rate, feed rate and influent, effluent and background concentrations were within the allowable parameters specified by the protocol as shown above in **Tables 5A and 5B**.

**Table 15 Barracuda MAX Summary of Removal Efficiency for 100% MTR**

Target Flow Rate (cfs)	Average Flow Rate (cfs)	Target Flow Rate (gpm)	Average Flow Rate (gpm)	Detention Time (min)	Run Length (min)	Max. Water Temp. (°F)	Influent Conc. (mg/L)	Adj. Effluent Conc. (mg/L)	Removal Efficiency (%)
1.52	1.54	682	692	0.86	24	47	190	106.2	44.1

**Table 16 Barracuda MAX Effluent and Background TSS for 100% MTR**

Sample ID	Run Time (min)	Effluent TSS (mg/L)	Background TSS (mg/L)	Reporting Limit Limit (mg/L)	Background TSS Used in Calc. (mg/L)	Adjusted Effluent TSS (mg/L)
1	3.5	94	4	1.0	4.0	90.0
2	4	107			4.5	102.5
3	4.5	118	5	1.0	5.0	113.0
4	8	109			4.5	104.5
5	8.5	111	4	1.0	4.0	107.0
6	9	111			3.5	107.5
7	12.5	107	3	1.0	3.0	104.0
8	13	105			3.5	101.5
9	13.5	109	4	1.0	4.0	105.0
10	17	108			4.0	104.0
11	17.5	113	4	1.0	4.0	109.0
12	18	118			2.5	115.5
13	21.5	110	1	1.0	1.0	109.0
14	22	110			1.0	109.0
15	22.5	113	1	1.0	1.0	112.0
Average						106.2

*\*Shaded background concentrations are interpolated.*



**Table 17A Barracuda MAX Doser Sample Data for 100% MTFR**

Sample ID	Time into Run (min)	Sample Mass (g)	Sample Duration (s)	Sediment Feed Rate (g/min)	Calculated Influent TSS (mg/L)
0	0	107.63	12.94	499.1	190
1	4.5	112.37	12.94	521.0	199
2	9	117.04	13.28	528.8	202
3	13.5	117.42	13.03	540.7	206
4	18	115.38	13.03	531.3	203
5	22.5	107.01	13.16	487.9	186
				Mean	518.1

**Table17B Barracuda MAX Influent Concentration for 100% MTFR**

Dosed Sediment Mass (g)	Dosing Duration (min)	Adjusted Influent Water (gallons)	Calc. Influent Feed TSS* (mg/L)
11524	23.13	16014	190.1

*\*Average influent concentration reported was calculated by dividing the entire mass of test sediment injected into the flow stream over the duration of the test by the total flow volume during the injection of test sediment.*

*Removal Efficiency Test Results for 125% MTFR*

The 125% MTFR test was conducted in accordance with the NJDEP HDS Protocol at a target flow rate of 1.90 cfs. A summary of the performance results for this run is shown in **Table 18** below. Background and effluent sampling measurements are presented in **Table 19**. Doser data and influent TSS concentration results are given in **Tables 20A and 20B**. The Barracuda MAX test unit removed 42.0% of the test sediment at a flow rate of 1.99 cfs. QA/QC results for flow rate, feed rate and influent, effluent and background concentrations were within the allowable parameters specified by the protocol as shown above in **Tables 5A and 5B**.

**Table 18 Barracuda MAX Summary of Removal Efficiency for 125% MTR**

Target Flow Rate (cfs)	Average Flow Rate (cfs)	Target Flow Rate (gpm)	Average Flow Rate (gpm)	Detention Time (min)	Run Length (min)	Max. Water Temp. (°F)	Influent Conc. (mg/L)	Adj. Effluent Conc. (mg/L)	Removal Efficiency (%)
1.90	1.99	853	893	0.69	21.5	48	212	123.2	42.0

**Table 19 Barracuda MAX Effluent and Background TSS for 125% MTR**

Sample ID	Run Time (min)	Effluent TSS (mg/L)	Background TSS (mg/L)	Reporting Limit Limit (mg/L)	Background TSS Used in Calc. (mg/L)	Adjusted Effluent TSS (mg/L)
1	3	112	1	1.0	1.0	111.0
2	3.5	123			0.8	122.3
3	4	123	ND	1.0	0.5	122.5
4	7	126			0.5	125.5
5	7.5	127	ND	1.0	0.5	126.5
6	8	126			0.5	125.5
7	11	132	ND	1.0	0.5	131.5
8	11.5	115			0.5	114.5
9	12	117	ND	1.0	0.5	116.5
10	15	129			0.5	128.5
11	15.5	135	ND	1.0	0.5	134.5
12	16	124			0.5	123.5
13	19	127	ND	1.0	0.5	126.5
14	19.5	121			0.5	120.5
15	20	119	ND	1.0	0.5	118.5
Average						123.2

*\*Shaded background concentrations are interpolated.*

**Table 20A Barracuda MAX Doser Sample Data for 125% MTFR**

Sample ID	Time into Run (min)	Sample Mass (g)	Sample Duration (s)	Sediment Feed Rate (g/min)	Calculated Influent TSS (mg/L)
0	0	115.09	10.63	649.6	192
1	4	115.56	10.65	651.0	193
2	8	123.68	10.56	702.7	208
3	12	131.07	10.62	740.5	219
4	16	114.78	10.65	646.6	191
5	20	121.60	10.53	692.9	205
				Mean	680.6

**Table 20B Barracuda MAX Influent Concentration for 125% MTFR**

Dosed Sediment Mass (g)	Dosing Duration (min)	Adjusted Influent Water (gallons)	Calc. Influent Feed TSS* (mg/L)
14929	20.79	18566	212.4

*\*Average influent concentration reported was calculated by dividing the entire mass of test sediment injected into the flow stream over the duration of the test by the total flow volume during the injection of test sediment.*

#### 4.2 Scour Test Results

Scour testing was conducted on the Barracuda MAX S4 model in accordance with Section 4 of the NJDEP HDS Protocol at a flow rate of 3.17 cfs (1425 gpm, slightly greater than 200% of the MTFR) to verify that the unit is suitable for on-line installation.

A summary of the QA/QC results for the scour run is provided in **Table 21**. A summary of the background and effluent concentrations is provided in **Table 22**. All background and effluent concentrations were less than or equal to 6 mg/L. The average adjusted effluent concentration was less than 2 mg/L when tested at greater than 200% of the MTFR. Based on these results, the Barracuda MAX is suitable for on-line installation.

**Table 21 QA/QC Results for Scour Run**

		QA/QC Requirement	PASS QA/QC?
Maximum Temperature (°F)	56.2	≤ 80 °F	YES
Ave. Flow Rate (cfs)	3.17		
Ave. Flow Rate (gpm)	1425		
Flow Rate COV	0.009	≤ 0.03	YES
Ave. Flow Rate % MTR	209	≥ 200	YES
Ave. Background TSS (mg/L)	0.5	≤ 20	YES
Ave. Adj. Effluent TSS (mg/L)	1.7	≤ 20	YES

**Table 22 Background and Effluent TSS Concentrations for Scour Run**

Sample #	Sample Time into Run (min)	Effluent TSS (mg/L)	Background TSS (mg/L)	Adjusted Effluent TSS (mg/L)
1	2	6	0.5	5.5
2	4	6		5.5
3	6	4	0.5	3.5
4	8	3		2.5
5	10	5	0.5	4.5
6	12	2		1.5
7	14	1	0.5	0.5
8	16	1		0.5
9	18	1	0.5	0.5
10	20	0.5		0
11	22	0.5	0.5	0
12	24	0.5		0
13	26	2	0.5	1.5
14	28	0.5		0
15	30	0.5	0.5	0
Average Adjusted TSS Concentration				1.7

*\*Shaded background concentrations are interpolated.*

### 4.3 Hydraulics

Flow and water level (head) measurements within the system were made for flow rates ranging from 171 gpm (0.38 cfs) to 852 gpm (1.90 cfs). Each test flow was set and operated at steady state, at which time two measurements were taken for each of five locations: in the influent pipe, inside the cone, over the weir (if applicable), behind the weir, and in the effluent pipe. Measurements within the influent and effluent pipes were taken at the entrance and exit of the unit. Flow rates were measured by the FloCat MFE electromagnetic flow meter, and water elevations were measured with a yard stick, under the supervision of BEC. All head measurements were made relative to the pipe invert. Data and calculated head losses are shown in **Table 23**. The flow rate at which the system went into bypass (i.e., water crested over the weir) was 733 gpm (1.63 cfs).

**Table 23 Recorded Flow and Head Elevation**

Flow		HEAD (in), Adjusted to Pipe Invert Where Applicable					System Loss <sup>C,D</sup>
(gpm)	(cfs)	Influent Pipe	Cone <sup>A</sup>	Over Weir <sup>B</sup>	Behind Weir	Effluent Pipe	(in)
171	0.38	3.50	4.50	N/A	4.00	3.50	0.00
172	0.38	3.25	4.50	N/A	3.75	3.50	0.00
340	0.76	5.00	6.50	N/A	5.00	5.25	0.00
341	0.76	5.25	6.50	N/A	5.00	5.25	0.00
558	1.24	10.00	11.00	N/A	7.50	9.00	1.00
557	1.24	9.75	11.00	N/A	7.25	9.00	0.75
687	1.53	11.75	13.25	N/A	8.00	10.75	1.00
685	1.53	12.00	13.50	N/A	8.00	10.75	1.25
725	1.62	BELOW BYPASS		N/A			
733	1.63	BYPASS POINT FLOW RATE		0.00			
741	1.65	BARELY BYPASS		0.125			
852	1.90	14.00	15.25	1.00 <sup>E</sup>	8.75	12.75	1.25
851	1.90	14.25	15.50	1.00 <sup>E</sup>	9.00	12.50	1.75

<sup>A</sup>The top of the cone is 2" below the pipe invert, and 0.0" head is defined as at the pipe invert.

<sup>B</sup>Height of Weir = 17" from top of cone, or 15" from pipe invert

<sup>C</sup>System Loss is defined as Head at Influent Pipe - Head at Effluent Pipe

<sup>D</sup>Negative results for calculated head loss are set to 0. A negative result is within the range of measurement.

<sup>E</sup>Head Over the Weir is greater than (Head in Cone – 15") due to the energy of flow against the weir.

## 5. Design Limitations

The Advanced Drainage Systems (ADS) Water Quality Team provides engineering support to all clients. Each system is designed and sized according to anticipated flow rate, load rating, and system depth at the installation site. All site and design constraints are discussed during the design and manufacturing process.

### *Required Soil Characteristics*

The Barracuda MAX is delivered to the job site to be housed in a pre-cast concrete structure or an ADS polypropylene manhole. During the pre-casting design process, soil characteristics, including corrosiveness, top and lateral loading, and groundwater must be addressed. The Barracuda MAX can be installed and will function in all soil types. A copy of the geotechnical report along with surface loading requirements, and groundwater situation must be reviewed and verified during the design process (see below for buoyancy situations).

### *Slope*

The Barracuda MAX is typically installed on a 0% slope or flat installation grade across the unit (invert in to invert out). In general, it is recommended that the pipe slope into the system not exceed 10%. Slopes in excess of 10% could cause increased velocities which could affect the turbulence into the system. The ADS Water Quality Engineering Team will evaluate the design prior to specification for application on sites with steep slopes.

### *Maximum Flow Rate*

The maximum treatment flow rate (MTFR) of the Barracuda MAX is dependent upon model size and performance specifications. The hydraulic loading rate is 54.2 gpm/ft<sup>2</sup> for all models. ADS Water Quality Engineering staff can assist site design engineers to ensure an appropriate model.

### *Maintenance Requirements*

The lifespan and maintenance needs of the Barracuda MAX depend on the sediment load and individual site conditions. The system must be inspected at regular intervals and maintained when necessary to ensure the optimal performance. Detailed requirements can be found in **Section 6**.

### *Driving Head*

Driving head will vary depending on the site-specific configuration. Design support is given by the ADS Water Quality Team for each project, and site-specific drawings (cut sheets) will be provided that show pipe inverts, finish surface elevation, and peak treatment and maximum flow rates through the Barracuda MAX to ensure no adverse impact on the hydraulic grade-line.

### *Installation Limitations*

The ADS Water Quality Team provides contractors with instructions prior to delivery, and onsite assistance is available from the installation technician during delivery and installations. Pick weights and lifting details are also provided prior to delivery to ensure that the contractor is able to prepare the appropriate equipment on site.

### *Configurations*

The Barracuda MAX is available in various configurations and can be installed on- or off-line, although this verification pertains to on-line installations. An internal bypass weir removes the need for any external high-flow diversion structure in the on-line system. When bypass occurs, flow is routed directly from the treatment chamber to the outlet chamber, thus preventing any scour or loss of captured pollutants. In some cases, inlet/outlet pipes with varying pipe angles can be accommodated; however, the performance of these configurations has not been verified by NJCAT. Other variants were not tested under this protocol; it is up to the governing jurisdiction to make the determination whether they can be used in projects under their purview. Contact the ADS Water Quality Team for design assistance on this.

### *Structural Load Limitations*

The Barracuda MAX is typically designed for HS-20 loading. If a depth greater than 15 feet is required from final grade, the manhole structural design must be reviewed by the manufacturer. Contact the ADS Water Quality Team if increasing load is expected.

### *Pre-treatment Requirements*

The Barracuda MAX has no pre-treatment requirements.

### *Limitations in Tailwater*

Site-specific tailwater conditions will be assessed on each individual project. Tailwater conditions increase the amount of driving head required for optimal system operation. The manufacturer's internal protocols require that these conditions are discussed with the engineer of record and that a solution be implemented to adjust for any design variations caused by tailwater conditions at both treatment and bypass flow rates.

### *Depth to Seasonal High Water Table*

Groundwater conditions do not affect Barracuda MAX function and treatment performance. High groundwater may cause buoyancy, and an anti-floatation ballast can be added to the structure to counteract this. If high groundwater is anticipated, the ADS Water Quality Engineering Team will evaluate the need for anti-buoyancy measures and provide the guidance to address the concerns.

## 6. Maintenance Plans

The Barracuda MAX requires periodic maintenance to continue operating at design efficiency. The maintenance process is comprised of the cleaning of the manhole with a vacuum truck. The system needs to be cleaned, when necessary, to ensure optimum performance, typically every 12-18 months. The rate at which the system collects pollutants will depend more upon site activities than the size of the unit. Since stormwater solids loads can be variable, it is possible that the maintenance cycle could be more or less than the projected duration for a given O&M cycle.

### *Inspection*

Inspection is the key to effective maintenance, and it is easily performed. The ADS Water Quality Team recommends the Barracuda MAX be inspected every six (6) months for the first year, and then on an annual basis. Sediment accumulation may be especially variable during the first year after installation as construction disturbances and landscaping stabilizes. Inspections may need to be performed more often in the winter months in climates where sanding operations may lead to rapid accumulations or in other areas with heavy sediment loading. It is particularly useful to keep a record of each inspection.

NJDEP requires that sediment be removed when the sediment depth reaches 50% of the MTD's maximum sediment storage capacity. The Barracuda MAX should be cleaned when inspection reveals that 10 inches or more of sediment is accumulated at the bottom of the manhole or when visual inspection shows a large accumulation of debris or oil. This determination of sediment depth can be made by lowering a stadia rod into the manhole until it hits the sediment and measuring the distance from the bottom of the pole to the water line mark on the stadia rod. Note: To avoid underestimating the volume of sediment in the manholes, the measuring device must be lowered to the top of the sediment pile carefully. Finer, silty particles at the top of the pile may offer less resistance to the end of the rod than larger particles toward the bottom of the pile.

Maintenance frequency can be determined by adhering to the initial sizing frequency given by the initial sizing of the system. Once actual sediment loading on-site is determined, a modified maintenance frequency can be proposed to the site owner. Please contact the ADS Water Quality Engineering Team for maintenance cycle estimations or assistance at 1.800.229.7283.

### *Maintenance Procedures*

1. Remove the manhole cover to provide access to the pollutant storage. Pollutants are stored in the sump, below the cone assembly visible from the surface. Access to this area is through the opening at the bottom of the cone.
2. Use a vacuum truck to remove all water, debris, oils, and sediment from both the top cone area and the bottom sump compartment area of the Barracuda MAX unit.
3. Use a high-pressure hose to clean the manhole of all remaining sediment and debris (recommended but optional). Then, use the vacuum truck to remove this water.
4. Fill the cleaned Barracuda MAX unit with water to the invert of the outlet pipe.
5. Replace the manhole cover/close the hatch (if applicable).



6. Dispose of polluted water, oils, sediment, and trash at an approved facility.
7. Local regulations prohibit the discharge of solid material into the sanitary system. Check with the local sewer authority for authority to discharge the liquid.
8. Many places treat the pollutants as leachate. Check with local regulators about disposal requirements. Important: Additional local regulations may apply to the maintenance procedure.

## **7. Statements**

The following signed statements from the manufacturer (Advanced Drainage Systems, Inc.), third-party observer (Boggs Environmental Consultants, Inc.), and NJCAT are required to complete the NJCAT verification process.

In addition, it should be noted that this report has been subjected to public review (e.g., stormwater industry), and all comments and concerns have been satisfactorily addressed.

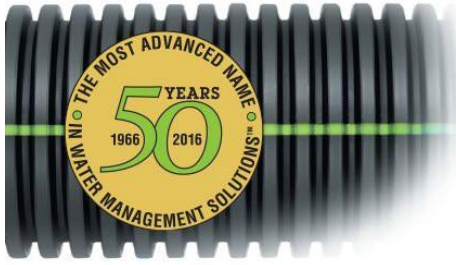

THE MOST **ADVANCED** NAME IN WATER MANAGEMENT SOLUTIONS™



January 26, 2021

Dr. Richard S. Magee, Sc.D., P.E., BCEE  
Executive Director  
New Jersey Corporation for Advanced Technology (NJCAT)  
c/o Center for Environmental Systems  
Stevens Institute of Technology  
One Castle Point on Hudson  
Hoboken, NJ 07030

RE: Manufacturer's Statement of Compliance for Barracuda™ MAX Hydrodynamic Separator

In accordance with the New Jersey Department of Environmental Protection (NJDEP) *Procedure for Obtaining Verification of a Stormwater Manufactured Treatment Device from New Jersey Corporation for Advanced Technology (NJCAT)* (January 25, 2013), Advanced Drainage Systems is pleased to provide this letter as our statement certifying that the protocol, *New Jersey Department of Environmental Protection Laboratory Protocol to Assess Total Suspended Solids Removal by a Hydrodynamic Sedimentation Manufactured Treatment Device* (NJDEP HS Protocol, January 25, 2013), was strictly followed while testing our Barracuda™ MAX Separator. The testing was performed at the BaySaver Laboratory, located in Mount Airy, MD, during November and December of 2020, under the supervision of Boggs Environmental Consultants, and was conducted in full compliance with all applicable protocol and process criteria. The preparation of the Verification Report and the documentation contained therein for the Barracuda™ MAX fulfill the submission requirements of the process document and the protocol.

Sincerely,

Daniel J Figola, PE

Director, Product Design  
Advanced Drainage Systems, Inc.



January 25, 2021

ATTENTION To Whom it May Concern

REFERENCE: Third Party Review of Testing Procedures of the Barracuda™ MAX Hydrodynamic Separator at the BaySaver Laboratory  
1207 Park Ridge Drive  
Mount Airy, MD 21771

BOGGS ENVIRONMENTAL CONSULTANTS, INC. (BEC) provided Third Party Review services for the testing of the Barracuda™ MAX Hydrodynamic Separator (Barracuda MAX) to evaluate if the required testing meets certification standards established by the procedures and testing requirements described below.

#### LABORATORY TESTING PROCEDURES & METHODOLOGIES

The following two procedures and testing requirements and/or guidelines were followed during the testing process of the Barracuda MAX manufactured treatment device (MTD).

- *New Jersey Department of Environmental Protection Laboratory Protocol to Assess Total Suspended Solids Removal by a Hydrodynamic Sedimentation Manufactured Treatment Device*, January 25, 2013.
- *Quality Assurance Project Plan (QAPP) for BaySaver Barracuda MAX Separator*, prepared by BaySaver Technologies, LLC, a subsidiary of Advanced Drainage Systems, Inc., October 2020, and approved by the New Jersey Corporation for Advanced Technology (NJCAT).

#### ONSITE THIRD-PARTY OBSERVATION OF TESTING PROCEDURES

BEC was present at the BaySaver Laboratory, at 1207 Park Ridge Drive, in Mount Airy, MD 21771, to observe and/or conduct the following:

- The establishment of a sediment blend for removal efficiency testing that included manufactured sands that when delivered to the feed water would result in influent Total Suspended Solids (TSS) concentrations within the established range of approximately 200 mg/L and a particle size distribution specified and approved by NJDEP.
- Verification that the false floor was installed in the proper location for the removal efficiency testing in accordance with the NJDEP Protocol.
- The establishment of a sediment blend for scour testing that included manufactured sands meeting the particle size distribution specified and approved by NJDEP, and verification that the false floor was located in the proper location and the sediment was pre-loaded for the scour run, in accordance with the NJDEP Protocol.
- Observation of five sediment removal efficiency runs and one scour run from November 24, 2020, to December 22, 2020, and completion of Procedure Checklists for each run to verify and document the following: pumps and measurement devices were turned on and functioning; the correct measurements of dry sediments were added to the doser and feed stream; sediment, background, and effluent samples were collected at established intervals during the run.
- Observation of the downloading of flow and temperature data and verification that sediment feed rates met the requirements of the NJDEP Protocol.
- Verification that sample containers were properly labeled, chain of custodies were completed, and samples were boxed and sealed for delivery to Fredericktowne Labs for TSS analysis.

**ENVIRONMENTAL SCIENCE, ENGINEERING & INDUSTRIAL HYGIENE SERVICES**



### THIRD-PARTY VERIFICATION & OPINIONS

Based on observations during the runs and the reported analytical results, BEC verified the following:

- That the testing of the Barracuda MAX at the BaySaver Laboratory was conducted in accordance with the following: *New Jersey Department of Environmental Protection Laboratory Protocol to Assess Total Suspended Solids Removal by a Hydrodynamic Sedimentation Manufactured Treatment Device*, January 25, 2013; and *Quality Assurance Project Plan (QAPP) for BaySaver Barracuda MAX Separator*, prepared by BaySaver Technologies, LLC, a subsidiary of Advanced Drainage Systems, Inc., October 2020, and approved by the New Jersey Corporation for Advanced Technology (NJCAT).
- The report titled *NJCAT Technology Verification of Barracuda™ MAX Hydrodynamic Separator*, prepared by Advanced Drainage Systems, Inc., dated January 2021, used applicable protocols described in the paragraph above and accurately reflects the testing observed by BEC.

BEC has no financial conflict of interest, as defined in the *Procedure for Obtaining Verification of a Stormwater Manufactured Treatment Device from New Jersey Corporation of Advanced Technology* (NJEP 2013).

Should you have any questions, contact our office at your earliest convenience.

Sincerely,

**BOGGS ENVIRONMENTAL CONSULTANTS, INC.**

William R. Warfel  
Principal Environmental Scientist

January 25, 2021

ATTENTION To Whom it May Concern

REFERENCE: No Conflict of Interest Statement for Third Party Review of Testing Procedures Conducted on the Barracuda™ MAX Hydrodynamic Separator at the BaySaver Technologies Laboratory  
1207 Park Ridge Drive  
Mount Airy, MD 21771

**BOGGS ENVIRONMENTAL CONSULTANTS, INC.** (BEC) was hired by BaySaver Technologies, LLC (a subsidiary of Advanced Drainage Systems, Inc.) to provide Third Party Review Services and onsite observations of test runs and analysis of the Barracuda™ MAX Hydrodynamic Separator (Barracuda MAX) to evaluate if the required testing meets established certification standards. Onsite observations and evaluations by BEC were conducted at the BaySaver Technologies Laboratory, 1207 Park Ridge Drive, Mount Airy, Maryland from November 24, 2020 to December 22, 2020.

I want to ensure you that there is no conflict of interest between BEC and BaySaver Technologies, LLC, or Advanced Drainage Systems, Inc., for the following reasons:

- BEC has no ownership stake in BaySaver Technologies, LLC, or Advanced Drainage Systems, Inc.
- BEC receives no commission for selling a manufactured treatment device for BaySaver Technologies, LLC, or Advanced Drainage Systems, Inc.
- BEC has no licensing agreement with BaySaver Technologies, LLC, or Advanced Drainage Systems, Inc., and
- BEC receives no funding or grants associated with the testing program from BaySaver Technologies, LLC, or Advanced Drainage Systems, Inc.

Please give me call if you have any questions.

Sincerely,  
**BOGGS ENVIRONMENTAL CONSULTANTS, INC.**



William R. Warfel  
Principal Environmental Scientist



**Center for Environmental Systems  
Stevens Institute of Technology  
One Castle Point  
Hoboken, NJ 07030-0000**

February 5, 2021

Gabriel Mahon, Chief  
NJDEP  
Bureau of Non-Point Pollution Control  
Bureau of Water Quality  
401 E. State Street  
Mail Code 401-02B, PO Box 420  
Trenton, NJ 08625-0420

Dear Mr. Mahon,

Based on my review, evaluation and assessment of the testing conducted on a full-scale, commercially available ADS Barracuda™ MAX Hydrodynamic Separator (Model S4) at ADS's BaySaver Laboratory in Mount Airy, MD. William Warfel, Boggs Environmental Consultants, Middletown, MD provided independent third-part oversight. The test protocol requirements contained in the "New Jersey Department of Environmental Protection Laboratory Protocol to Assess Total Suspended Solids Removal by a Hydrodynamic Sedimentation Manufactured Treatment Device" (NJDEP Filter Protocol, January 2013) were met consistent with the NJDEP Approval Process. Specifically:

*Test Sediment Feed*

The sediment used for removal efficiency tests was a blend of high purity commercially available silica sand. Under the supervision of BEC, twenty subsamples, taken from varying locations within the test sediment five covered bins, were composited. Three random samples were collected from the composite and analyzed for PSD and moisture content according to ASTM D422-63 (2007) by ECS Mid-Atlantic, LLC. The sediment met the NJDEP Protocol specifications for removal efficiency testing and the  $d_{50}$  of the sediment was 65  $\mu\text{m}$ , significantly less than the NJDEP specification of  $<75 \mu\text{m}$ . The average moisture content was determined to be 0.067%.

### *Scour Test Sediment*

The test sediment used for scour testing was a blend of high purity commercially available silica sand. The test sediment was batched, labeled, and stored in seven covered bins for the duration of this project. Under the supervision of BEC, twenty-eight subsamples, taken from various locations within the test sediment containers, were composited, and then three random samples collected from the composite sample were sent to ECS Mid-Atlantic, LLC, for PSD analysis using method ASTM D422-63. The sediment met the NJDEP Protocol specifications.

### *Removal Efficiency Testing*

Removal efficiency testing followed the effluent grab sampling test method outlined in Section 5 of the NJDEP Protocol. The weighted sediment removal efficiency of the Barracuda™ MAX Hydrodynamic Separator (Model S4) (MTFR 682 gpm, 1.52 cfs) was 55.5%.

### *Scour Testing*

Scour testing of the Barracuda™ MAX Hydrodynamic Separator (Model S4) was conducted in accordance with Section 4 of the NJDEP Protocol at a target flow rate greater than 200% of the Barracuda™ MAX MTFR to qualify the MTD for online installation. The average test flow rate was 3.17 cfs or 209% of the 1.52 cfs MTFR. The average adjusted effluent SSC for this test was 1.7 mg/L, well below the maximum allowable SSC of 20 mg/L, qualifying the Barracuda™ MAX for on-line installation.

Sincerely,



Richard S. Magee, Sc.D., P.E., BCEE

## 8. References

ASTM D422-63. *Standard Test Method for Particle-Size Analysis of Soils*.

ASTM D3977-97. *Standard Test Methods for Determining Concentrations in Water Samples*.

BaySaver Technologies, LLC 2020. *Quality Assurance Project Plan for BaySaver Barracuda MAX Separator*. Prepared by BaySaver Technologies, LLC, a subsidiary of Advanced Drainage Systems, Inc. October 2020.

BaySaver Technologies, LLC 2017. *NJCAT Technology Verification: BaySaver Barracuda™ Hydrodynamic Separator*. Prepared by BaySaver Technologies, LLC. September 2017.

NJDEP 2013a. *New Jersey Department of Environmental Protection Procedure for Obtaining Verification of a Stormwater Manufactured Treatment Device from New Jersey Corporation for Advanced Technology*. Trenton, NJ. January 25, 2013.

NJDEP 2013b. *New Jersey Department of Environmental Protection Laboratory Protocol to Assess Total Suspended Solids Removal by a Hydrodynamic Sedimentation Manufactured Treatment Device*. Trenton, NJ. January 25, 2013.



## **VERIFICATION APPENDIX**

### ***Introduction***

- Manufacturer –Advanced Drainage Systems, Inc., 1030 Deer Hollow Drive, Mt. Airy, MD 21771. Website: <http://www.BaySaver.com> Phone: 800-229-7283.
- Barracuda MAX MTD – Barracuda™ MAX verified models are shown in **Table A-1** and **Table A-2**.
- TSS Removal Rate – 50%
- On-line installation

### ***Detailed Specification***

- NJDEP sizing tables and physical dimensions of the Barracuda MAX verified models are attached (**Table A-1** and **Table A-2**).
- New Jersey requires that the peak flow rate of the NJWQ Design Storm event of 1.25 inch in 2 hours shall be used to determine the appropriate size for the MTD. The Barracuda MAX S4 Model has a maximum treatment flow rate (MTFR) of 1.52 cfs (682 gpm), which corresponds to a surface loading rate of 54.2 gpm/ft<sup>2</sup> of sedimentation area.
- Pick weights and installation procedures vary slightly with model size. Design support is given by the ADS Water Quality Team for each project and pick weights and installation procedures will be provided prior to delivery.
- Maximum sediment depth is 20 inches for all model sizes. The recommended sediment depth prior to cleanout is 10 inches.
- Maintenance Guide is at: [MG1.01-Barracuda-Max-Maintenance-Guide-2-21.pdf \(baysaver.com\)](http://www.baysaver.com/Files/MG1.01-Barracuda-Max-Maintenance-Guide-2-21.pdf)
- Maintenance frequency for the Barracuda MAX models is 49 months.
- Under N.J.A.C. 7:8-5.5, NJDEP stormwater design requirements do not allow a hydrodynamic separator such as the Barracuda MAX to be used in series with another hydrodynamic separator to achieve an enhanced TSS removal rate.

**Table A-1 MTFRs and Sediment Removal Intervals for Barracuda™ MAX Models**

<b>Model<sup>1</sup></b>	<b>Manhole Diameter<sup>1</sup> (ft)</b>	<b>NJDEP 50% TSS Maximum Treatment Flow Rate (cfs)</b>	<b>Treatment Area (ft<sup>2</sup>)</b>	<b>Hydraulic Loading rate (gpm/ft<sup>2</sup>)</b>	<b>50% Maximum Sediment Storage<sup>2</sup> (ft<sup>3</sup>)</b>	<b>Sediment Removal Interval<sup>3</sup> (months)</b>
Barracuda MAX S3	3	0.85	7.07	54.2	5.89	49
Barracuda MAX S4	4	1.52	12.57	54.2	10.47	49
Barracuda MAX S5	5	2.37	19.63	54.2	16.36	49
Barracuda MAX S6	6	3.40	28.27	54.2	23.56	49
Barracuda MAX S8	8	6.08	50.27	54.2	41.89	49
Barracuda MAX S10	10	9.48	78.54	54.2	65.45	49

Notes:

1. In some areas Barracuda MAX units are available in additional diameters. Units not listed here are sized not to exceed 54.2 gpm/ft<sup>2</sup> of effective treatment during the peak water quality flow.
2. 50% Sediment Storage Capacity is equal to Treatment Area x 10 inches of sediment depth. Each Barracuda MAX unit has a 20-inch deep sediment sump.
3. Sediment Removal Interval (months) = (50% HDS MTD Max Sediment Storage Volume \* 3.57) / (MTFR \* TSS Removal Efficiency) calculated using equation in Appendix B, Part B of the NJDEP HDS Protocol.

**Table A-2 Standard Dimensions for Barracuda™ MAX Models**

<b>Model</b>	<b>Manhole Diameter (ft)</b>	<b>NJDEP 50% TSS MTFR (cfs)</b>	<b>Total Chamber Depth (ft)</b>	<b>Treatment Chamber Depth<sup>1</sup> (ft)</b>	<b>Treatment Chamber Wet Volume<sup>2</sup> (ft<sup>3</sup>)</b>	<b>Aspect Ratio<sup>3</sup> (Depth/Dia.)</b>	<b>Sediment Sump Depth (in)</b>	<b>Maximum Pipe Diameter (in)</b>
Barracuda MAX S3	3	0.85	5.00	4.17	29.5	1.39	20.0	18.0
Barracuda MAX S4	4	1.52	7.08	6.25	78.6	1.56	20.0	30.0
Barracuda MAX S5	5	2.37	7.08	6.25 <sup>3</sup>	122.7	1.25	20.0	42.0
Barracuda MAX S6	6	3.40	7.08	6.25 <sup>3</sup>	176.7	1.04	20.0	48.0
Barracuda MAX S8	8	6.08	11.44	10.61	533.4	1.326	20.0	72.0
Barracuda MAX S10	10	9.48	14.09	13.26	1041.4	1.326	20.0	96.0

Notes:

1. Treatment chamber depth is defined as the total chamber depth minus ½ the sediment storage depth.
2. Referred to as Treatment Chamber Capacity in the ADS Barracuda MAX Maintenance Guide.
3. The aspect ratio for the tested unit is 1.56. Larger models (>250% MTFR of the tested unit, > 3.80 cfs) must be geometrically proportionate to the tested unit. A variance of 15% is allowable (1.326 to 1.794).
4. For units < 250% MTFR (5 and 6 ft models), the depth must be equal or greater than the depth of the unit treated.