



## State of New Jersey

PHILIP D. MURPHY  
*Governor*

SHEILA Y. OLIVER  
*Lt. Governor*

Division of Water Quality  
Bureau of Nonpoint Pollution Control  
401 East State Street  
P.O. Box 420 Mail Code 401-02B  
Trenton, New Jersey 08625-0420  
Phone: 609-633-7021 / Fax: 609-777-0432  
[http://www.state.nj.us/dep/dwq/bnpc\\_home.htm](http://www.state.nj.us/dep/dwq/bnpc_home.htm)

CATHERINE R. McCABE  
*Commissioner*

**February 10, 2020**

Jeremy Fink, P.E.  
Principal Product Development Engineer  
Hydro International  
94 Hutchins Drive  
Portland, ME 04102

Re: MTD Laboratory Certification  
Up-Flo<sup>®</sup> Filter EMC (Extended Maintenance Cartridge)  
Off-line Installation

### **TSS Removal Rate 80%**

Dear Mr. Fink:

The Stormwater Management rules under N.J.A.C. 7:8-5.5(b) and 5.7(c) allow the use of manufactured treatment devices (MTDs) for compliance with the design and performance standards at N.J.A.C. 7:8-5 if the pollutant removal rates have been verified by the New Jersey Corporation for Advanced Technology (NJCAT) and have been certified by the New Jersey Department of Environmental Protection (NJDEP). Hydro International has requested a Laboratory Certification for the Up-Flo<sup>®</sup> Filter EMC.

This project falls under the "Procedure for Obtaining Verification of a Stormwater Manufactured Treatment Device from New Jersey Corporation for Advanced Technology" dated January 25, 2013. The applicable protocol is the "New Jersey Department of Environmental Protection Laboratory Protocol to Assess Total Suspended Solids Removal by a Filtration Manufactured Treatment Device" dated January 25, 2013.

NJCAT verification documents submitted to the NJDEP indicate that the requirements of the aforementioned protocol have been met or exceeded. The NJCAT letter also included a recommended certification TSS removal rate and the required maintenance plan. The NJCAT Verification Report with the Verification Appendix (dated January 2020) for this device is published online at <http://www.njcat.org/uploads/newDocs/NJCATUPFLOFILTERwithEXTMAINTCARTFINAL.pdf>.

**The NJDEP certifies the use of the Up-Flo<sup>®</sup> Filter EMC by Hydro International at a TSS removal rate of 80%, when designed, operated and maintained in accordance with the information provided in the Verification Appendix and subject to the following conditions:**

1. The maximum treatment flow rate (MTFR) for the manufactured treatment device (MTD) is calculated using the New Jersey Water Quality Design Storm (1.25 inches in 2 hrs) in N.J.A.C. 7:8-5.5. The MTFR is calculated based on a verified loading rate of 0.96 gpm/sf of effective filtration treatment area.
2. The Up-Flo<sup>®</sup> Filter EMC shall be installed using the same configuration as the unit verified by NJCAT and sized in accordance with the criteria specified in item 6 below.
3. This device cannot be used in series with another MTD or a media filter (such as a sand filter), to achieve an enhanced removal rate for total suspended solids (TSS) removal under N.J.A.C. 7:8-5.5.
4. Additional design criteria for MTDs can be found in Chapter 9.6 of the New Jersey Stormwater Best Management Practices (NJ Stormwater BMP) Manual which can be found on-line at [www.njstormwater.org](http://www.njstormwater.org).
5. The maintenance plan for a site using this device shall incorporate, at a minimum, the maintenance requirements for the Up-Flo<sup>®</sup> Filter EMC, which is attached to this document. However, it is recommended to review the maintenance website at [https://www.hydro-int.com/sites/default/files/up-flo\\_filter\\_emc\\_operation\\_maintenance\\_manual.pdf](https://www.hydro-int.com/sites/default/files/up-flo_filter_emc_operation_maintenance_manual.pdf) for any changes to the maintenance requirements.
6. Sizing Requirements:

The example below demonstrates the sizing procedure for an Up-Flo<sup>®</sup> Filter EMC. After determining the number of filter modules necessary, the corresponding model selection must be appropriate to hold at least that minimum number of filters.

Example: A 0.25-acre impervious site is to be treated to 80% TSS removal using an Up-Flo<sup>®</sup> Filter EMC. The impervious site runoff (Q) based on the New Jersey Water Quality Design Storm was determined to be 0.79 cfs or 354.58 gpm.

The selection of configuration for use in the Up-Flo<sup>®</sup> Filter EMC is based upon both the MTFR and the maximum inflow drainage area. It is necessary to select the configuration using both methods and to rely on the method that results in the larger configuration determined by the two methods.

#### Inflow Drainage Area Evaluation:

The drainage area to the Up-Flo<sup>®</sup> Filter EMC in this example is 0.25 acres. Based upon the information in Tables 1 and 2 below, the following minimum

configuration is required for an Up-Flo® Filter EMC to treat the impervious area without exceeding the maximum drainage area:

Using Table 2, all vault sizes for the 18”, 27”, 36” and 48” cartridges would be able to treat runoff without exceeding the maximum allowable drainage area. A minimum of 5, 4, 3, or 2 cartridges for the 18”, 27”, 36”, or 48” cartridge sizes, respectively, would be required to avoid exceeding the maximum allowable drainage area.

Maximum Treatment Flow Rate (MTFR) Evaluation:

The site runoff (Q) was determined based on the following:

time of concentration = 10 minutes

i = 3.2 in/hr (page 5-8, Fig. 5-3 of the NJ Stormwater BMP Manual)

c = 0.99 (runoff coefficient for impervious)

Q = ciA = 0.99 x 3.2x 0.25=0.79 cfs = 0.79 x 448.83 gpm/cfs = 354.58 gpm

Based on a flow rate of 354.58 gpm, the following minimum configurations are required for an Up-Flo® Filter EMC to treat the impervious area without exceeding the MTFR:

For 18” cartridge: 8 x 18.5 ft. vault size with 66 cartridges

For 27” cartridge: 8 x 10 ft. or 6 x 14 ft. vault size with 40 cartridges

For 36” cartridge: 8 x 8 ft. or 6 x 10 ft. vault size with 29 cartridges

For 48” cartridge: 6 x 8 ft. vault size with 21 cartridges

The MTFR evaluation results will be used since that method results in the higher minimum configuration determined by the two methods.

The sizing table corresponding to the available system models are noted in the Design Specifications and Vault Arrangements noted below.

**Table 1: Up-Flo® Filter EMC Cartridge Design Specifications**

Individual Cartridge Height (inches)	MTFR (gpm)	MTFR (cfs)	Max Drainage Area Per Cartridge (acre)
18	5.40	0.012	0.05
27	8.90	0.020	0.08
36	12.4	0.028	0.12
48	17.0	0.038	0.16

**Table 2: Up-Flo® Filter EMC Typical Vault Arrangements\***

Vault Size (ft.)	Width (ft.)	Vault Length (ft.)	18-inch Cartridge			27-inch Cartridge			36-inch Cartridge			48-inch Cartridge		
			Max. No. Carts.	MTFR (cfs)	Max Drain Area (ac)	Max. No. Carts.	MTFR (cfs)	Max Drain Area (ac)	No. Carts.	MTFR (cfs)	Max Drain Area (ac)	Max. No. Carts.	MTFR (cfs)	Max Drain Area (ac)
4x4	4	4	6	0.071	0.31	6	0.118	0.51	6	0.165	0.71	6	0.227	0.97
4x6	4	6	11	0.134	0.57	11	0.218	0.93	11	0.303	1.29	11	0.417	1.78
4x8	4	8	15	0.180	0.77	15	0.296	1.27	15	0.412	1.76	15	0.568	2.43
6x6	6	6	17	0.205	0.87	17	0.336	1.44	17	0.468	2.00	15	0.568	2.43
6x8	6	8	24	0.290	1.23	24	0.475	2.03	23	0.633	2.70	23	0.871	3.72
6x10	6	10	31	0.374	1.59	30	0.595	2.54	30	0.827	3.53	28	1.061	4.53
6x12	6	12	38	0.459	1.95	37	0.733	3.13	35	0.965	4.12	34	1.288	5.50
6x14	6	14	45	0.541	2.31	44	0.871	3.72	41	1.130	4.82	39	1.477	6.31
8x8	8	8	32	0.385	1.65	31	0.613	2.62	30	0.827	3.53	29	1.098	4.69
8x10	8	10	41	0.495	2.11	40	0.791	3.38	38	1.047	4.47	36	1.364	5.82
8x13	8	13	55	0.664	2.83	49	0.970	4.14	50	1.377	5.88	46	1.742	7.44
8x14	8	14	59	0.711	3.03	57	1.130	4.82	53	1.459	6.23	49	1.856	7.92
8x15	8	15	63	0.760	3.24	61	1.208	5.15	57	1.571	6.70	53	2.007	8.57
8x18.5	8	18.5	80	0.965	4.12	75	1.484	6.34	70	1.927	8.23	64	2.424	10.35
8x24	8	24	102	1.230	5.25	96	1.900	8.11	87	2.397	10.23	79	2.992	12.77

\*-Vault sizes are noted with the maximum number of cartridges.

Be advised a detailed maintenance plan is mandatory for any project with a Stormwater BMP subject to the Stormwater Management Rules, N.J.A.C. 7:8. The plan must include all of the items identified in Stormwater Management Rules, N.J.A.C. 7:8-5.8. Such items include, but are not limited to, the list of indication of problems in the system, and training of maintenance personnel. Additional information can be found in Chapter 8: Maintenance and Retrofit of Stormwater Management Measures.

If you have any questions regarding the above information, please contact Anthony Robalik or Minesh Patel of my office at (609) 633-7021.

Sincerely,

A handwritten signature in blue ink that reads "Gabriel Mahon". The signature is written in a cursive style with a large initial 'G'.

Gabriel Mahon, Chief  
Bureau of Nonpoint Pollution Control

Attachment: Maintenance Plan

cc: Chron File  
Richard Magee, NJCAT  
Vince Mazzei, NJDEP - DLUR  
James Murphy, NJDEP - BNPC  
Anthony Robalik NJDEP – BNPC  
Minesh Patel NJDEP – BNPC

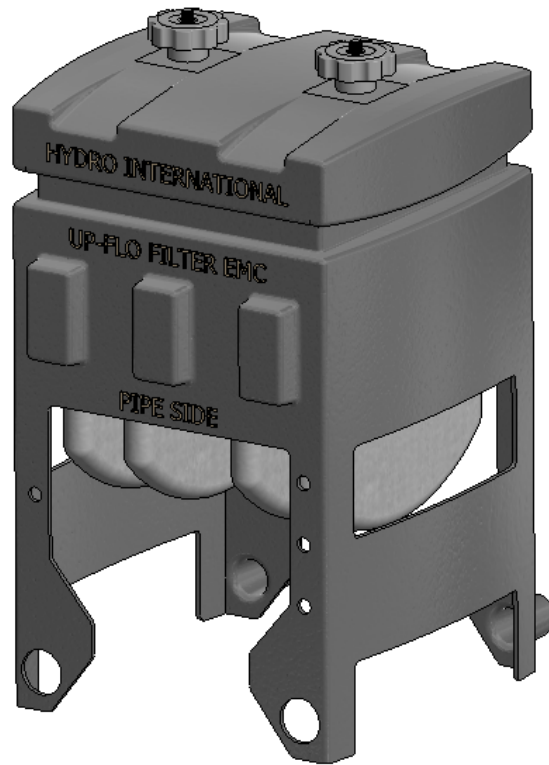

# Up-Flo Filter® Extended Maintenance Cartridge Operation and Maintenance Manual

October 2019  
Rev. A

## Contents

Overview and Product Description.....	3
Operation.....	4
Introduction.....	4
Pollutant Capture.....	4
Best Practices.....	4
Damage Due to Lack of Maintenance.....	4
Inspection & Maintenance.....	4
Overview.....	4
Inspection and Maintenance.....	5
Routine Inspection.....	5
Routine Inspection Procedures.....	5
Routine Maintenance.....	5
Maintenance Scheduling.....	6
Recommended Equipment.....	6
Surface Maintenance Procedure.....	6
Filter Cartridge Replacement.....	7
Up-Flo® Filter Installation Log.....	8
Up-Flo® Filter Inspection Log.....	9
Up-Flo® Filter Maintenance Log.....	11

## Overview and Product Description

The Up-Flo® Filter is a modular high-rate stormwater filtration device designed to capture trash, oil, sediment and remove fine pollutants such as particulate metals and nutrients from stormwater runoff. Designed with efficiency, longevity and upkeep in mind, this high performance, low maintenance filter option that offers higher loading rates and longer membrane life for higher quality stormwater for longer periods between servicing. In general, a minimum of two inspections are required per year to monitor sediment and gross pollutant accumulations. In order to achieve an annual TSS removal rate of 80% for the Up-Flo® Filter, the minimum maintenance frequency specified in the maintenance section for replacement of the filter inserts and removal of accumulated sediment from the sump is mandatory.

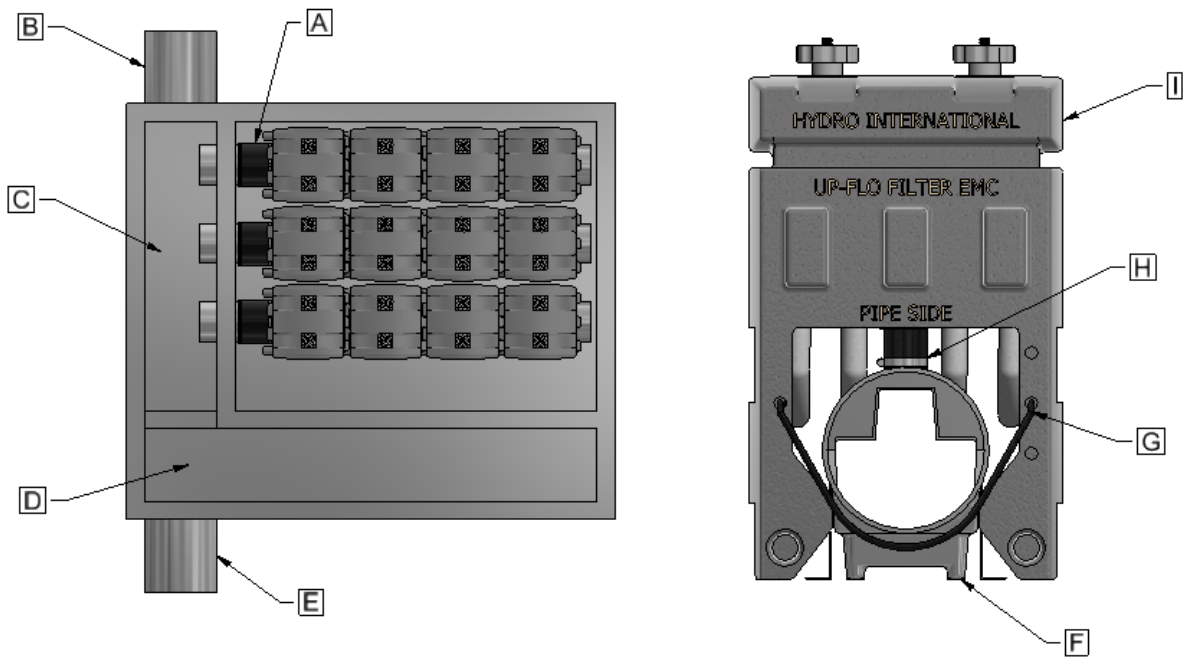

System Components			
A.	Underdrain Coupling	F.	Underdrain
B.	Outlet Pipe	G.	Cartridge Restraining Cord
C.	Outlet Bay	H.	Cartridge Connection Boot
D.	Inlet Bay	I.	Filter Cartridge
E.	Inlet Pipe		

Figure 1: The Up-Flo® Filter EMC



## Operation

### Introduction

The Up-Flo® Filter operates on simple fluid hydraulics. It is self-activating, has no moving parts, no external power requirements and is fabricated with durable non-corrosive components. Personnel are not required to operate the unit and maintenance is limited to periodic inspections, sediment and floatables removal and cartridge replacement.

### Pollutant Capture

The Up-Flo® Filter is designed to operate as a “treatment train” by incorporating multiple treatment technologies into a single device. Trash and gross debris are removed by sedimentation and screening before they are introduced to the filtration membranes, delaying surface blinding. The Up-Flo® Filter is a wet-sump device. Between storm events, oil and floatables are stored on the water surface separate from the sediment storage volume in the sump.

### Best Practices

Good housekeeping upstream of the Up-Flo® Filter can significantly extend maintenance interval. For example, sweeping paved surfaces, collecting leaves and grass trimmings, and protecting bare ground from erosion will reduce loading to the system. The filter cartridges should not be installed until construction activities are complete and site stabilization is effective.

### Damage Due to Lack of Maintenance

Delayed maintenance would result in clogged filters. In that situation, an Up-Flo® Filter could go into bypass and there would be no treatment of the incoming stormwater. Replacement of the filter cartridges and removal of sediment from the sump would restore the Up-Flo® Filter to its original treatment efficiency. Establishing and adhering to a regular maintenance schedule ensures optimal performance of the system.

## Inspection & Maintenance

### Overview

The Up-Flo® Filter protects the environment by removing a wide range of pollutants from stormwater runoff. Periodic removal of these captured pollutants is essential to the proper functioning of the Up-Flo® Filter.

Replacement of filter cartridges must be performed inside the vessel. A vactor truck is required for removal of oils, water, sediment, and to completely pump out the vessel to allow for maintenance inside. If you are not using Hydro International or a trained service provider, you must follow OSHA (or other regional) Confined Space Entry procedures when entering the Up-Flo® vessel.

**The minimum required frequency for replacement of the filter cartridges is annually**, whereas the minimum required frequency for removal of accumulated sediment from the sump is dependent on the Up-Flo® Filter configuration. Configurations with a larger sediment storage volume per module will require less frequent removal of accumulated sediment. Regardless, whenever sediment depth in the sump is found to be greater than 6 inches (15 cm), sediment removal is required.

## Inspection and Maintenance

### Routine Inspection

Inspection is a simple process that requires monitoring pollutant accumulations. Maintenance crews should be familiar with the Up-Flo® Filter and its components prior to inspection.

**The following instructions are intended for non-Hydro maintenance service providers and/or those intending to maintain their own Up-Flo® Filter:**

### Routine Inspection Procedures

1. Set up any necessary safety equipment (such as traffic cones) to provide access to the Up-Flo® Filter. Safety equipment should notify passing pedestrian and road traffic that work is being done.
2. Remove the grate or lid to the manhole or vault.
3. Without entering the vessel, look down into the chamber to inspect the inside and to make note of any irregularities.
4. Without entering the vessel, use the pole with the skimmer net to remove floatables and loose debris from the chamber.
5. Using a sediment probe such as a Sludge-Judge®, measure the depth of sediment that has collected in the sump of the vessel. Maximum sediment depth is 6 inches (15 cm).
6. On the Maintenance Log provided by Hydro International, record the date, unit location, estimated volume of floatables and gross debris removed, and the depth of sediment measured. Also note any apparent irregularities such as damaged components or a high standing water level.
7. Securely replace the grate or lid.
8. Remove safety equipment.
9. Contact Hydro International to discuss any irregularities noted during inspection.

### Routine Maintenance

The access port located at the top of the manhole or vault provides access to the Up-Flo® vessel for maintenance personnel to enter the vessel and remove and replace filter cartridges. The same access would be used for maintenance personnel working from the surface to vector out sediment, oil, and water (Figure 2). Unless the Up-Flo® Filter has been installed in a very shallow configuration, it is necessary to have personnel with OSHA Confined Space Entry training performing the maintenance that occurs inside the vessel.

Maintenance intervals are determined from monitoring the Up-Flo® Filter during its first year of operation. Depending on the site, some maintenance activities may have to be performed on a more frequent basis than others.

A vector truck is normally required for oil removal, removal of sediment from the sump, and to dewater the vessel for replacement of the filter cartridges. All inspection and maintenance activities would be recorded in an Inspection and Maintenance Log.

The access port located at the top of the manhole provides unobstructed access for a vector hose and/or skimmer pole to be lowered to the base of the sump.



Figure 2: Sediment is removed from the sump with a vactor hose. Confined space entry is not required for this step.

## Maintenance Scheduling

- Call Hydro International to order replacement filter cartridges prior to scheduling maintenance.
- Because filter cartridge replacement requires entry into the Up-Flo® chamber, maintenance events should be scheduled during dry weather.
- Filter cartridge replacement should occur immediately after a contaminated spill in the contributing drainage area.

## Recommended Equipment

- Safety Equipment (traffic cones, etc.)
- Crow bar to remove grate or lid
- Vactor truck (flexible hose preferred)
- Pressure nozzle attachment
- OSHA Confined Space Entry Equipment
- Replacement Up-Flo® Filter Cartridges (available from Hydro International)
- Hydro International Up-Flo® Filter Maintenance Log
- Screwdriver (flat head)

## Surface Maintenance Procedure

1. Set up any necessary safety equipment (such as traffic cones) around the access of the Up-Flo® Filter. Safety equipment should notify passing pedestrian and road traffic that work is being done.
2. Remove the grate or lid to the manhole or vault.
3. Without entering the vessel, look down into the chamber to inspect the inside. Make note of any irregularities.
4. Once all floatables and oil have been removed, drop the vactor hose to the base of the sump. Vactor out the sediment and gross debris from the sump floor.

5. Retract the vacuum hose from the vessel.
6. On the Maintenance Log provided by Hydro International, record the date, unit location, estimated volume of floatables, oils, and gross debris removed, and the depth of sediment measured. Note any apparent irregularities such as damaged components or blockages.
7. Securely replace the grate or lid. Remove safety equipment.
8. Dispose of sediment and gross debris following local regulations.
9. Dispose of oil and sump water at a licensed water treatment facility or following local regulations.
10. Contact Hydro International to discuss any irregularities noted during cleanout.

## Filter Cartridge Replacement

1. Following OSHA or region specific Confined Space Entry procedures, enter the Up-Flo® Filter Chamber.
2. Starting at the end of the filter cartridge row furthest from the Outlet Bay (Figure 1, Item C) remove each Filter Cartridge (Figure 1, Item I) from the Underdrain (Figure 1, Item A) as described below:
  - a. Unfasten Cartridge Restraining Cord (Figure 1, Item G)
  - b. Loosen Cartridge Connection Boot (Figure 1, Item H) using flathead screwdriver
  - c. Remove Filter Cartridge and transfer to surface.
3. Starting at the end of the Underdrain closest to the Outlet Bay, install new Filter Cartridges, supplied by Hydro International.
  - Orient Filter Cartridge with the labeled "Pipe Side" facing away from the Outlet Bay.
  - Tighten Cartridge Connection Boot using flathead screwdriver
  - Fasten Cartridge Restraining Cord
4. Exit the Up-Flo® Filter chamber and securely replace the grate or lid.
5. On the Maintenance Log provided by Hydro International, record the date, unit location, estimated volume of floatables, oil and gross debris removed, and the depth of sediment measured. Note the number of filter cartridges replaced. Note any irregularities such as damaged components or blockages.
6. Remove safety equipment.
7. Return spent filter cartridges to Hydro International for refurbishment.
8. Contact Hydro International to discuss any irregularities noted during annual maintenance.

## Up-Flo® Filter Installation Log

<b>SITE REFERENCE NAME OR NUMBER FOR THIS UP-FLO® FILTER LOCATION:</b>	
<b>SITE NAME:</b>	
<b>SITE LOCATIONS:</b>	
<b>OWNER:</b>	<b>SITE CONTRACTOR:</b>
<b>CONTACT NAME:</b>	<b>CONTACT NAME:</b>
<b>COMPANY NAME:</b>	<b>COMPANY NAME:</b>
<b>ADDRESS:</b>	<b>ADDRESS:</b>
<b>TELEPHONE:</b>	<b>TELEPHONE:</b>
<b>FAX:</b>	<b>FAX:</b>

INSTALLATION DATE: \_\_\_\_ / \_\_\_\_ / \_\_\_\_

TOTAL NUMBER OF UP-FLO® FILTER CARTRIDGES: \_\_\_\_\_

# Up-Flo<sup>®</sup> Filter Inspection Log

Site Name: \_\_\_\_\_

Location: \_\_\_\_\_

Owner Name: \_\_\_\_\_

Address: \_\_\_\_\_ Phone Number: \_\_\_\_\_

Site Status: \_\_\_\_\_

Date: \_\_\_\_\_ Time: \_\_\_\_\_ Site Conditions\*: \_\_\_\_\_

\*(Stable, Under Construction, Needing Maintenance, etc.)

Inspection Frequency Key: A=annual; M=Monthly; S=after major storms

Inspection Items		Inspection Frequency	Inspected? (Y/N)	Maintenance Needed? (Y/N)	Comments/Description
<b>Debris Removal</b>	Adjacent area free of debris?				
	Inlets and outlets free of debris?				
	Facility (internally) free of debris?				
<b>Vegetation</b>	Surrounding area fully stabilized?				
	Grass mowed?				
<b>Water retention where required</b>	Water holding chamber(s) at normal pool				
	Evidence of erosion?				
<b>Sediment deposition</b>	Filtration chamber free of sediments?				
	Sedimentation sump not more than 50% full?				
<b>Structural components</b>	Any evidence of structural deterioration?				
	Grates in good condition?				
	Spalling or cracking of structural parts?				
	Outlet/overflow spillway				
<b>Other</b>	Noticeable odors?				
	Any evidence of filter(s) clogging?				
	Evidence of flow bypassing facility?				

Inspector Comments: \_\_\_\_\_

Overall Condition of Up-Flo® Filter\*\*: Acceptable / Unacceptable

\*\*Acceptable would mean properly functioning; unacceptable would mean damaged or required further maintenance

If any of the above Inspection Items are checked "Yes" for "Maintenance Needed", list Maintenance actions and their completion dates below or on the Maintenance Log provided on page 11 of the Up-Flo® Filter Operation & Maintenance Manual:

Maintenance Action Needed	Due Date

The next routine inspection is scheduled for approximately: (date) \_\_\_\_\_

Inspected by: (signature) \_\_\_\_\_

Inspected by: (printed) \_\_\_\_\_

---

## Up-Flo<sup>®</sup> Filter Maintenance Log

Site Name: \_\_\_\_\_

Location: \_\_\_\_\_

Owner Name: \_\_\_\_\_

Address: \_\_\_\_\_ Phone Number: \_\_\_\_\_

Site Status: \_\_\_\_\_

Date: \_\_\_\_\_ Time: \_\_\_\_\_ Site Conditions\*: \_\_\_\_\_

\*(Stable, Under Construction, Needing Maintenance, etc.)

Estimated volume of oil/floatable trash removed: \_\_\_\_\_

Sediment depth measured in sump prior to removal: \_\_\_\_\_

Number of Filter Cartridges replaced: \_\_\_\_\_

Inspector Comments: \_\_\_\_\_

---

Overall Condition of Up-Flo<sup>®</sup> Filter\*\*: Acceptable / Unacceptable

\*\*Acceptable would mean properly functioning; unacceptable would mean damaged or required further maintenance

Maintained by: (signature) \_\_\_\_\_

Maintained by: (printed) \_\_\_\_\_